

PF15

e-cad
Drawings
Available

GEARBOXES

Precision Worm Gear Reducers

Flange Input 0.94 – 3.75 Nm **6.66:1 - 80:1**

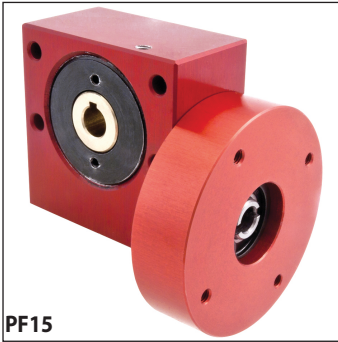

PF15

Input Detail

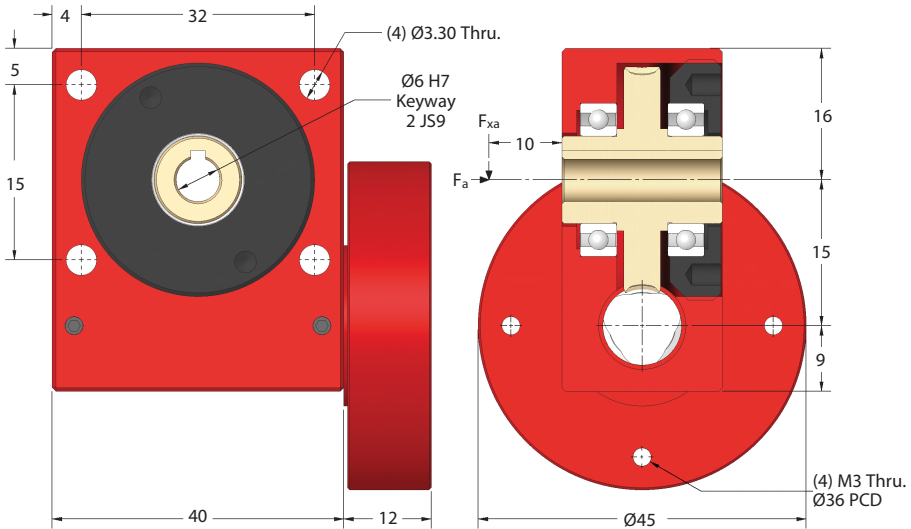
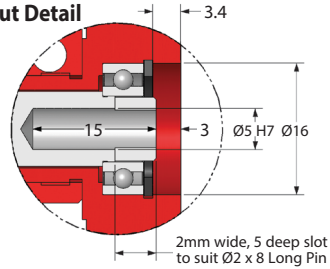

Standard $\leq 30^\circ$	Part Number Low Backlash $\leq 8'$	Red. Backlash $\leq 4'$	Ratio	Efficiency at 1000 Rpm	Reflected Inertia at Input (kg.m ²)	Self Locking Output
PF15-6	PF15-6A	PF15-6AR	6.66:1	86%	1.79×10^{-7}	✘
PF15-8	PF15-8A	PF15-8AR	8:1	85%	1.73×10^{-7}	✘
PF15-10	PF15-10A	PF15-10AR	10:1	84%	1.68×10^{-7}	✘
PF15-13	PF15-13A	PF15-13AR	13.33:1	78%	1.65×10^{-7}	✘
PF15-20	PF15-20A	PF15-20AR	20:1	71%	1.62×10^{-7}	✘
PF15-40	PF15-40A	PF15-40AR	40:1	60%	1.61×10^{-7}	✘
PF15-80	PF15-80A	PF15-80AR	80:1	32%	1.60×10^{-7}	✘

Accessories

- P20-X Single Output Shafts
- P20-DX Double Output Shafts
- KK2-20 Output Key

Weight: 0.21 kg. Greased for Life: Shell Gadus S5 V42P 2.5.
F_{xa} at 1000 Rpm: 8 kg, F_a at 1000 Rpm: 3 kg.

Tapped holes on input flange are not relative in position to the gearbox body and will alter from box to box. However, we can machine the tapped holes after assembly so they are relative in position to the gearbox body. This will affect delivery.

Motor Inputs also available.

Testing in your application is necessary.

You will need to assess duty cycles and confirm gearbox suitability with your own calculations.

All figures listed are to be used for guidance only.

Output Torque Nm

Rpm Input	Reduction Ratio						
	6.66:1	8:1	10:1	13.33:1	20:1	40:1	80:1
3000	1.05	1.13	1.20	1.28	1.43	1.58	0.94
2000	1.28	1.28	1.35	1.35	1.58	1.80	1.07
1000	1.58	1.73	1.73	1.88	2.03	2.18	1.28
500	2.03	2.03	2.10	2.18	2.40	2.63	1.46
200	2.55	2.63	2.63	2.78	2.93	3.08	1.70
100	2.93	2.93	3.08	3.15	3.23	3.38	1.91
50	3.30	3.38	3.38	3.45	3.53	3.60	2.04
10	3.60	3.60	3.68	3.68	3.75	3.75	2.04

GEARBOXES

Precision Worm Gear Reducers

Flange Input 8.3 – 33.2 lbf.in **6.66:1 - 80:1**

e-cad
Drawings
Available

PFA15

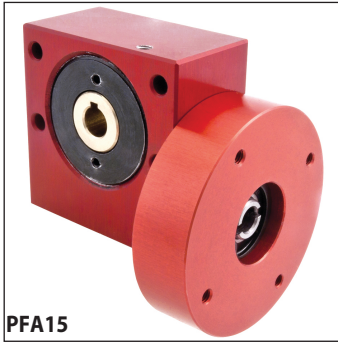

PFA15

Input Detail

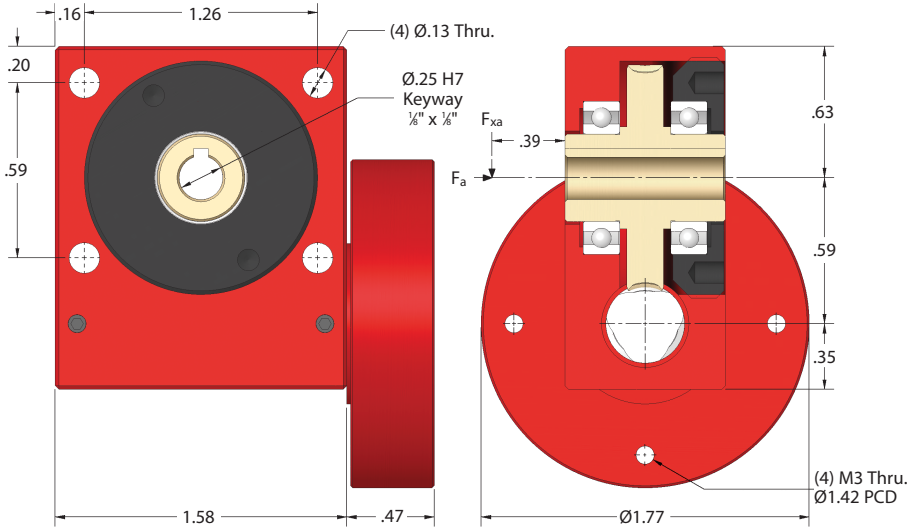
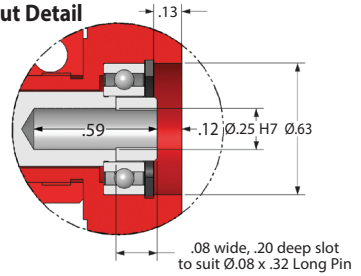

Standard ≤30'	Part Number Low Backlash ≤8'	Red. Backlash ≤4'	Ratio	Efficiency at 1000 Rpm	Reflected Inertia at Input (lb.in ²)	Self Locking Output
PFA15-6	PFA15-6A	PFA15-6AR	6.66:1	86%	6.12 x 10 ⁻⁴	✘
PFA15-8	PFA15-8A	PFA15-8AR	8:1	85%	5.91 x 10 ⁻⁴	✘
PFA15-10	PFA15-10A	PFA15-10AR	10:1	84%	5.74 x 10 ⁻⁴	✘
PFA15-13	PFA15-13A	PFA15-13AR	13.33:1	78%	5.64 x 10 ⁻⁴	✘
PFA15-20	PFA15-20A	PFA15-20AR	20:1	71%	5.54 x 10 ⁻⁴	✘
PFA15-40	PFA15-40A	PFA15-40AR	40:1	60%	5.50 x 10 ⁻⁴	✘
PFA15-80	PFA15-80A	PFA15-80AR	80:1	32%	5.47 x 10 ⁻⁴	✘

Weight: 0.46 lb. Greased for Life: Shell Gadus S5 V42P 2.5.
F_a at 1000 Rpm: 17.63 lb. F_a at 1000 Rpm: 6.61 lb.

Tapped holes on input flange are not relative in position to the gearbox body and will alter from box to box. However, we can machine the tapped holes after assembly so they are relative in position to the gearbox body. This will affect delivery.

Motor Inputs also available.

Testing in your application is necessary.

You will need to assess duty cycles and confirm gearbox suitability with your own calculations. All figures listed are to be used for guidance only.

Output Torque lbf.in

Rpm	Reduction Ratio						
Input	6.66:1	8:1	10:1	13.33:1	20:1	40:1	80:1
3000	9.3	10.0	10.6	11.3	12.7	14.0	8.3
2000	11.3	11.3	11.9	11.9	14.0	15.9	9.5
1000	14.0	15.3	15.3	16.6	18.0	19.3	11.3
500	18.0	18.0	18.6	19.3	21.2	23.3	12.9
200	22.6	23.3	23.3	24.6	25.9	27.3	15.0
100	25.9	25.9	27.3	27.9	28.6	29.9	16.9
50	29.2	29.9	29.9	30.5	31.2	31.9	18.1
10	31.9	31.9	32.6	32.6	33.2	33.2	18.1

sales@ondrives.us
www.ondrives.us

516-771-6777
516-771-6444

ondrives.US Corp.

PF20

e-cad
Drawings
Available

GEARBOXES

Precision Worm Gear Reducers

Flange Input 1.25 – 5 Nm **5:1 - 120:1**

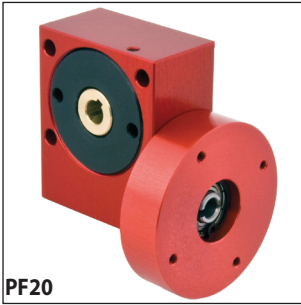

PF20

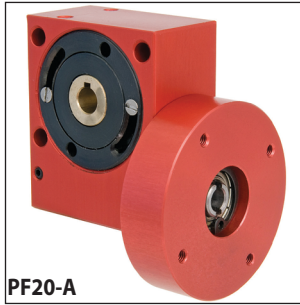

PF20-A

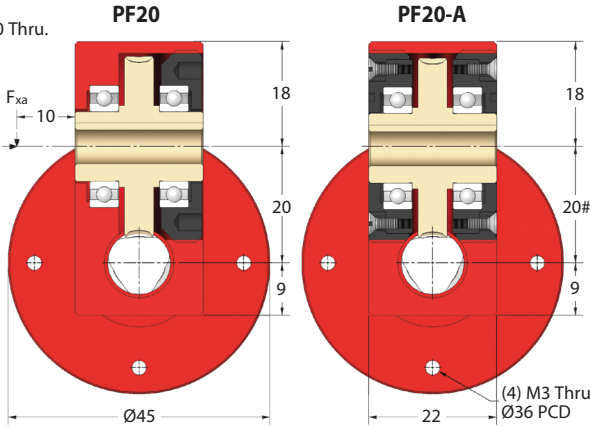
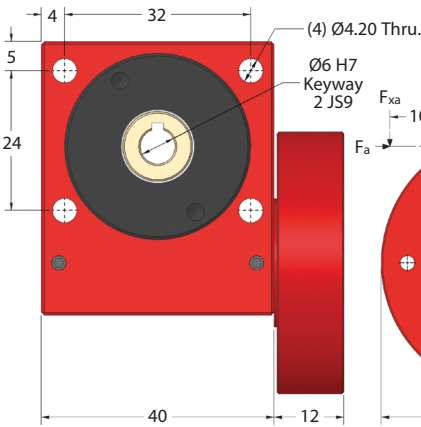
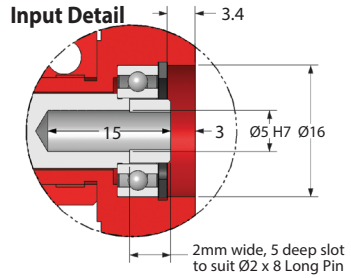

PF20A version (low backlash) output is on eccentric so centres will vary

Standard ≤30'	Low Backlash ≤8'	Red. Backlash ≤4'	Ratio	Efficiency at 1000 Rpm	Reflected Inertia at Input (kg.m ²)	Self Locking Output
PF20-10	PF20-10A	PF20-10AR	10:1	86%	2.53 x 10 ⁻⁷	✘
PF20-12	PF20-12A	PF20-12AR	12:1	85%	2.43 x 10 ⁻⁷	✘
PF20-15	PF20-15A	PF20-15AR	15:1	84%	2.35 x 10 ⁻⁷	✘
PF20-20	PF20-20A	PF20-20AR	20:1	78%	2.28 x 10 ⁻⁷	✘
PF20-30	PF20-30A	PF20-30AR	30:1	71%	2.24 x 10 ⁻⁷	✘
PF20-60	PF20-60A	PF20-60AR	60:1	60%	2.21 x 10 ⁻⁷	✓
PF20-120	PF20-120A	PF20-120AR	120:1	32%	2.00 x 10 ⁻⁷	✓
PF20-SP	PF20-SPA	PF20-SPAR	5:1-120:1	Special Ratios : Replace SP with required ratio		

Accessories

P20-X	Single Output Shafts
P20-DX	Double Output Shafts
KK2-20	Output Key

Weight: 0.23 kg. Greased for Life: Shell Gadus S5 V42P 2.5.
F_{xa} at 1000 Rpm: 12 kg. F_a at 1000 Rpm: 5 kg.

Tapped holes on input flange are not relative in position to the gearbox body and will alter from box to box. However, we can machine the tapped holes after assembly so they are relative in position to the gearbox body. This will affect delivery.

Motor Inputs also available.

Testing in your application is necessary.

You will need to assess duty cycles and confirm gearbox suitability with your own calculations.

All figures listed are to be used for guidance only.

Output Torque Nm

Rpm Input	Reduction Ratio						
	10:1	12:1	15:1	20:1	30:1	60:1	120:1
3000	1.40	1.50	1.60	1.70	1.90	2.10	1.25
2000	1.70	1.70	1.80	1.80	2.10	2.40	1.42
1000	2.10	2.30	2.30	2.50	2.70	2.90	1.70
500	2.70	2.70	2.80	2.90	3.20	3.50	1.94
200	3.40	3.50	3.50	3.70	3.90	4.10	2.27
100	3.90	3.90	4.10	4.20	4.30	4.50	2.55
50	4.40	4.50	4.50	4.60	4.70	4.80	2.72
10	4.80	4.80	4.90	4.90	5.00	5.00	2.72

GEARBOXES

Precision Worm Gear Reducers

Flange Input 11.1 – 44.3 lbf.in **5:1 - 120:1**

e-cad
Drawings
Available

PFA20

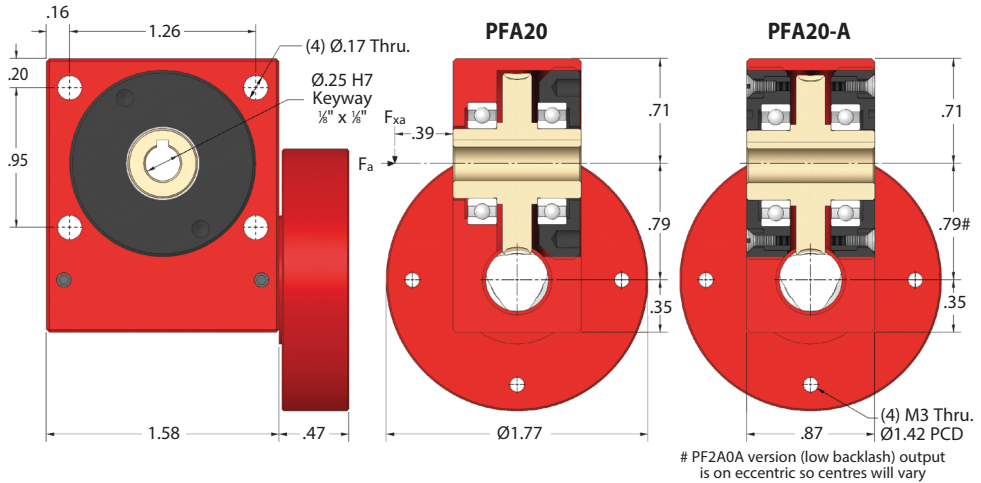
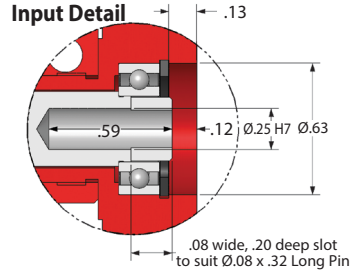
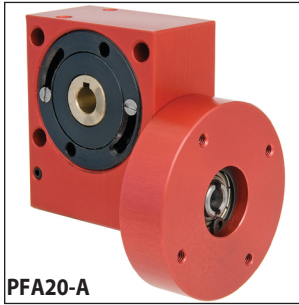
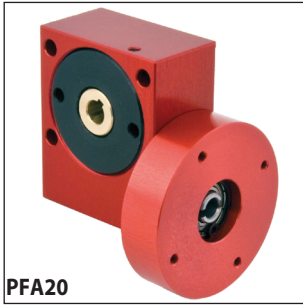

Standard ≤30'	Part Number Low Backlash ≤8'	Red. Backlash ≤4'	Ratio	Efficiency at 1000 Rpm	Reflected Inertia at Input (lb.in ²)	Self Locking Output
PFA20-10	PFA20-10A	PFA20-10AR	10:1	86%	8.65 x 10 ⁻⁴	✘
PFA20-12	PFA20-12A	PFA20-12AR	12:1	85%	8.30 x 10 ⁻⁴	✘
PFA20-15	PFA20-15A	PFA20-15AR	15:1	84%	8.03 x 10 ⁻⁴	✘
PFA20-20	PFA20-20A	PFA20-20AR	20:1	78%	7.79 x 10 ⁻⁴	✘
PFA20-30	PFA20-30A	PFA20-30AR	30:1	71%	7.65 x 10 ⁻⁴	✘
PFA20-60	PFA20-60A	PFA20-60AR	60:1	60%	7.55 x 10 ⁻⁴	✔
PFA20-120	PFA20-120A	PFA20-120AR	120:1	32%	6.83 x 10 ⁻⁴	✔
PFA20-SP	PFA20-SPA	PFA20-SPAR	5:1-120:1	Special Ratios : Replace SP with required ratio		

Weight: 0.51 lb. Greased for Life: Shell Gadus S5 V42P 2.5.
F_a at 1000 Rpm: 26.46 lb. F_a at 1000 Rpm: 11.02 lb.

Tapped holes on input flange are not relative in position to the gearbox body and will alter from box to box. However, we can machine the tapped holes after assembly so they are relative in position to the gearbox body. This will affect delivery.

Motor Inputs also available.

Testing in your application is necessary.

You will need to assess duty cycles and confirm gearbox suitability with your own calculations. All figures listed are to be used for guidance only.

Output Torque lbf.in

Rpm Input	Reduction Ratio						
	10:1	12:1	15:1	20:1	30:1	60:1	120:1
3000	12.4	13.3	14.2	15.0	16.8	18.6	11.1
2000	15.0	15.0	15.9	15.9	18.6	21.2	12.6
1000	18.6	20.4	20.4	22.1	23.9	25.7	15.0
500	23.9	23.9	24.8	25.7	28.3	31.0	17.2
200	30.1	31.0	31.0	32.7	34.5	36.3	20.1
100	34.5	34.5	36.3	37.2	38.1	39.8	22.6
50	38.9	39.8	39.8	40.7	41.6	42.5	24.1
10	42.5	42.5	43.4	43.4	44.3	44.3	24.1

PF30

e-cad
Drawings
Available

GEARBOXES

Precision Worm Gear Reducers

Flange Input 2.5 – 8.8 Nm **5:1 - 120:1**

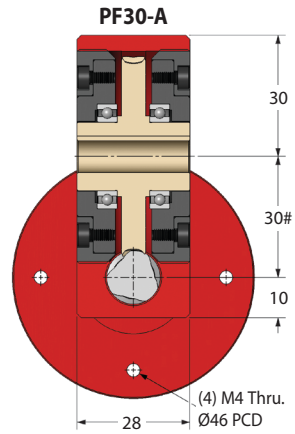
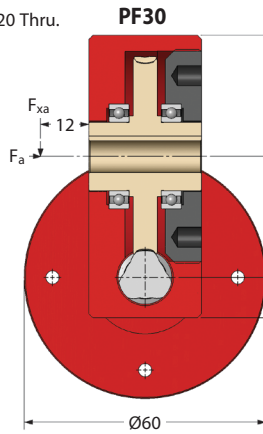
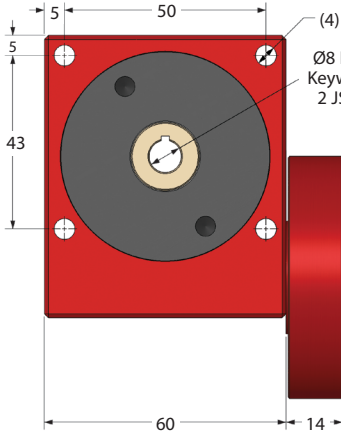
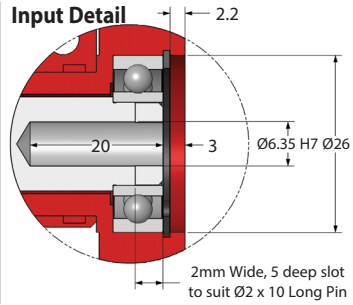
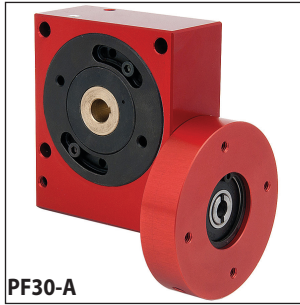
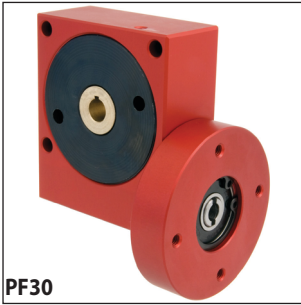

PF30A version (low backlash) output is on eccentric so centres will vary

Standard ≤30'	Part Number Low Backlash ≤8'	Red. Backlash ≤4'	Ratio	Efficiency at 1000 Rpm	Reflected Inertia at Input (kg.m ²)	Self Locking Output
PF30-10	PF30-10A	PF30-10AR	10:1	90%	1.00 x 10 ⁻⁶	✗
PF30-12	PF30-12A	PF30-12AR	12:1	88%	9.25 x 10 ⁻⁷	✗
PF30-15	PF30-15A	PF30-15AR	15:1	86%	8.62 x 10 ⁻⁷	✗
PF30-20	PF30-20A	PF30-20AR	20:1	84%	8.13 x 10 ⁻⁷	✗
PF30-30	PF30-30A	PF30-30AR	30:1	78%	7.88 x 10 ⁻⁷	✗
PF30-60	PF30-60A	PF30-60AR	60:1	70%	7.67 x 10 ⁻⁷	✓
PF30-120	PF30-120A	PF30-120AR	120:1	40%	7.42 x 10 ⁻⁷	✓
PF30-SP	PF30-SPA	PF30-SPAR	5:1-120:1	Special Ratios : Replace SP with required ratio		

Accessories	
P30-X	Single Output Shafts
P30-DX	Double Output Shafts
KK2-20	Output Key

Weight: 0.59 kg. Greased for Life: Shell Gadus S5 V42P 2.5.
F_{xa} at 1000 Rpm: 20 kg. F_a at 1000 Rpm: 12 kg.

Tapped holes on input flange are not relative in position to the gearbox body and will alter from box to box. However, we can machine the tapped holes after assembly so they are relative in position to the gearbox body. This will affect delivery.

Motor Inputs also available.

Testing in your application is necessary.

You will need to assess duty cycles and confirm gearbox suitability with your own calculations.

All figures listed are to be used for guidance only.

Output Torque Nm

Rpm Input	Reduction Ratio						
	10:1	12:1	15:1	20:1	30:1	60:1	120:1
3000	2.5	2.5	2.6	2.7	3.0	3.5	3.4
2000	2.8	2.9	3.0	3.2	3.6	4.1	3.7
1000	3.5	3.7	4.0	4.2	4.5	5.0	4.6
500	4.6	4.7	4.9	5.1	5.3	5.8	5.4
200	5.4	5.6	5.7	5.9	6.2	6.6	6.4
100	6.0	6.0	6.5	6.5	7.0	7.5	6.7
50	7.5	7.8	8.0	8.3	8.3	8.6	6.7
10	8.0	8.0	8.3	8.5	8.5	8.8	6.7

GEARBOXES

Precision Worm Gear Reducers

Flange Input 22.1 – 77.9 lbf.in **5:1 - 120:1**

e-cad
Drawings
Available

PFA30



PFA30

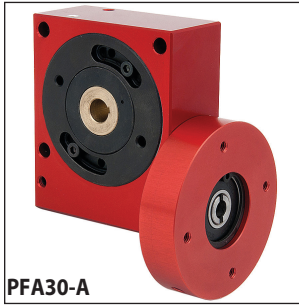

PFA30-A

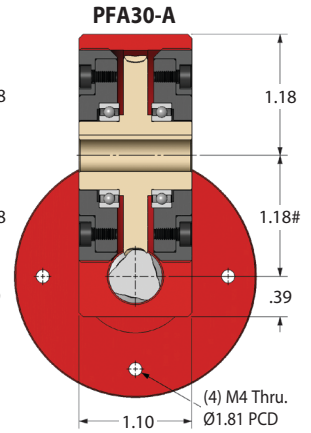
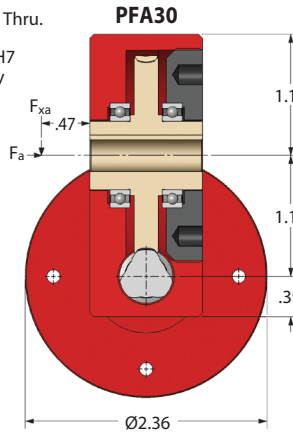
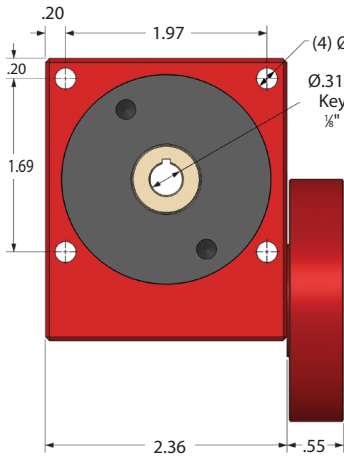
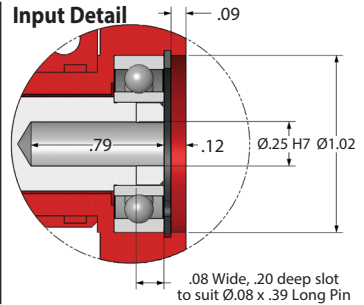

PFA30A version (low backlash) output is on eccentric so centres will vary

Standard ≤30'	Part Number Low Backlash ≤8'	Red. Backlash ≤4'	Ratio	Efficiency at 1000 Rpm	Reflected Inertia at Input (lb.in ³)	Self Locking Output
PFA30-10	PFA30-10A	PFA30-10AR	10:1	90%	3.42 x 10 ⁻³	✗
PFA30-12	PFA30-12A	PFA30-12AR	12:1	88%	3.16 x 10 ⁻³	✗
PFA30-15	PFA30-15A	PFA30-15AR	15:1	86%	2.95 x 10 ⁻³	✗
PFA30-20	PFA30-20A	PFA30-20AR	20:1	84%	2.78 x 10 ⁻³	✗
PFA30-30	PFA30-30A	PFA30-30AR	30:1	78%	2.08 x 10 ⁻³	✗
PFA30-60	PFA30-60A	PFA30-60AR	60:1	70%	2.62 x 10 ⁻³	✓
PFA30-120	PFA30-120A	PFA30-120AR	120:1	40%	2.54 x 10 ⁻³	✓
PFA30-SP	PFA30-SPA	PFA30-SPAR	5:1-120:1	Special Ratios : Replace SP with required ratio		

Weight: 1.30 lb. Greased for Life: Shell Gadus S5 V42P 2.5.
F_a at 1000 Rpm: 44.09 lb. F_a at 1000 Rpm: 26.46 lb.

Tapped holes on input flange are not relative in position to the gearbox body and will alter from box to box. However, we can machine the tapped holes after assembly so they are relative in position to the gearbox body. This will affect delivery.

Motor Inputs also available.

Testing in your application is necessary.

You will need to assess duty cycles and confirm gearbox suitability with your own calculations.

All figures listed are to be used for guidance only.

Output Torque lbf.in

Rpm Input	Reduction Ratio						
	10:1	12:1	15:1	20:1	30:1	60:1	120:1
3000	22.1	22.1	23.0	23.9	26.6	31.0	30.1
2000	24.8	25.7	26.6	28.3	31.9	36.3	32.7
1000	31.0	32.7	35.4	37.2	39.8	44.3	40.7
500	40.7	41.6	43.4	45.1	46.9	51.3	47.8
200	47.8	49.6	50.4	52.2	54.9	58.4	56.6
100	53.1	53.1	57.5	57.5	62.0	66.4	59.3
50	66.4	69.0	70.8	73.5	73.5	76.1	59.3
10	70.8	70.8	73.5	75.2	75.2	77.9	59.3

PF40

e-cad
Drawings
Available

GEARBOXES

Precision Worm Gear Reducers

Flange Input 5 – 18 Nm **5:1 - 120:1**

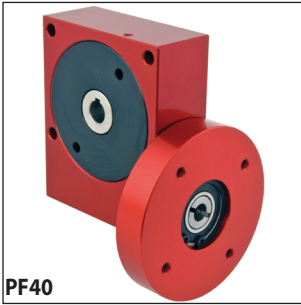

PF40

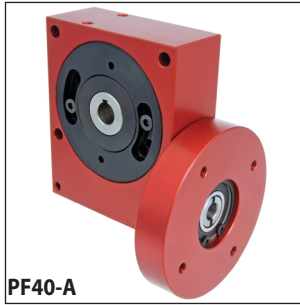

PF40-A

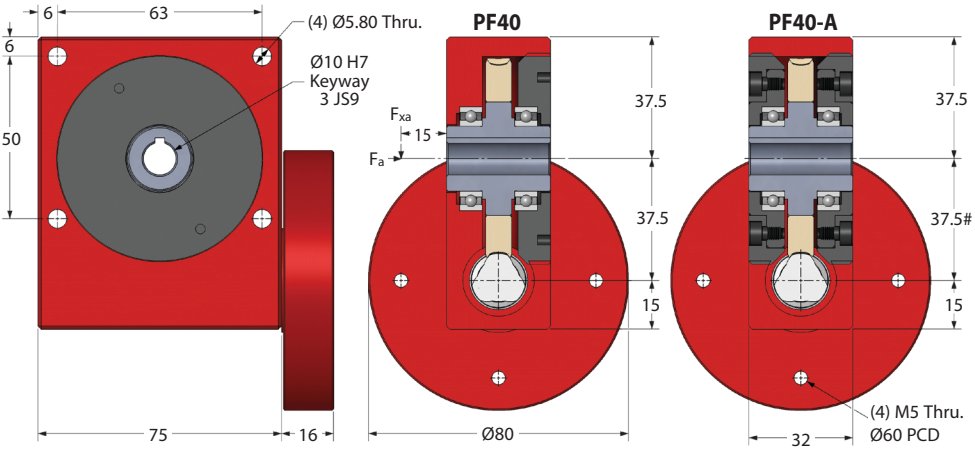
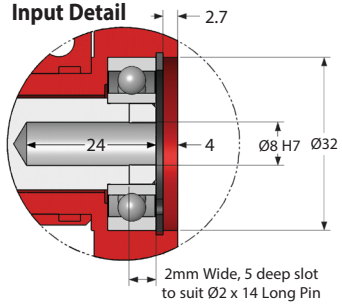

PF40A version (low backlash) output is on eccentric so centres will vary

Standard $\leq 30'$	Low Backlash $\leq 8'$	Red. Backlash $\leq 4'$	Ratio	Efficiency at 1000 Rpm	Reflected Inertia at Input (kg.m ²)	Self Locking Output
PF40-10	PF40-10A	PF40-10AR	10:1	89%	3.78×10^{-6}	✗
PF40-12	PF40-12A	PF40-12AR	12:1	87%	3.62×10^{-6}	✗
PF40-15	PF40-15A	PF40-15AR	15:1	85%	3.49×10^{-6}	✗
PF40-20	PF40-20A	PF40-20AR	20:1	83%	3.39×10^{-6}	✗
PF40-30	PF40-30A	PF40-30AR	30:1	76%	3.32×10^{-6}	✗
PF40-60	PF40-60A	PF40-60AR	60:1	65%	3.27×10^{-6}	✓
PF40-120	PF40-120A	PF40-120AR	120:1	41%	3.26×10^{-6}	✓
PF40-SP	PF40-SPA	PF40-SPAR	5:1-120:1	Special Ratios : Replace SP with required ratio		

Accessories	
P40-X	Single Output Shafts
P40-DX	Double Output Shafts
KK3-20	Output Key

Weight: 1.15 kg. Greased for Life: Shell Gadus S5 V42P 2.5.
F_{xa} at 1000 Rpm: 30 kg. F_a at 1000 Rpm: 20 kg.

Tapped holes on input flange are not relative in position to the gearbox body and will alter from box to box. However, we can machine the tapped holes after assembly so they are relative in position to the gearbox body. This will affect delivery.

Motor Inputs also available.
Testing in your application is necessary.
You will need to assess duty cycles and confirm gearbox suitability with your own calculations.
All figures listed are to be used for guidance only.

Output Torque Nm

Rpm Input	Reduction Ratio						
	10:1	12:1	15:1	20:1	30:1	60:1	120:1
3000	5.0	5.2	5.4	5.6	6.4	7.2	6.5
2000	5.5	5.8	6.2	6.6	7.3	8.0	7.2
1000	7.1	7.5	8.0	8.2	9.0	10.0	8.7
500	8.9	9.1	9.6	10.0	10.5	11.4	10.2
200	11.6	11.9	12.3	12.5	13.5	14.2	11.7
100	13.4	13.6	14.1	14.6	15.3	16.0	12.3
50	15.1	15.5	16.2	16.4	17.3	17.6	12.3
10	17.6	17.6	17.6	17.7	17.8	18.0	12.3

GEARBOXES

Precision Worm Gear Reducers

Flange Input 44.3 – 159.3 lbf.in **5:1 - 120:1**

e-cad
Drawings
Available

PFA40

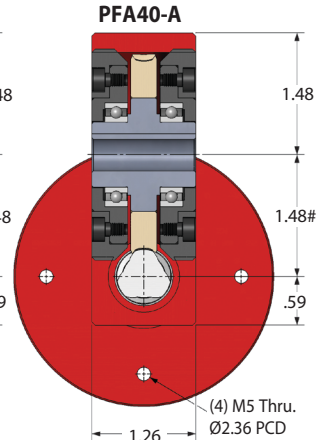
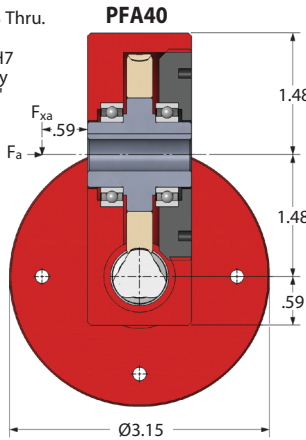
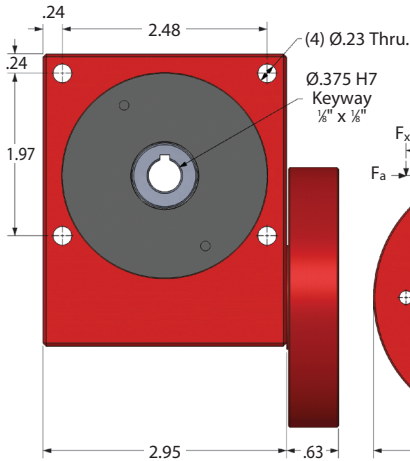
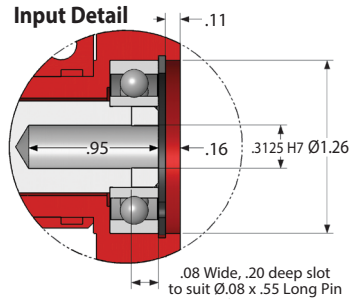
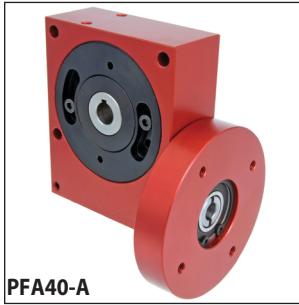
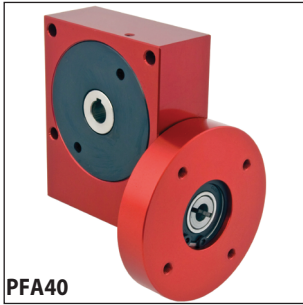

PFA40A version (low backlash) output is on eccentric so centres will vary

Standard ≤30'	Part Number Low Backlash ≤8'	Red. Backlash ≤4'	Ratio	Efficiency at 1000 Rpm	Reflected Inertia at Input (lb.in ²)	Self Locking Output
PFA40-10	PFA40-10A	PFA40-10AR	10:1	89%	1.29 x 10 ⁻²	✗
PFA40-12	PFA40-12A	PFA40-12AR	12:1	87%	1.24 x 10 ⁻²	✗
PFA40-15	PFA40-15A	PFA40-15AR	15:1	85%	1.19 x 10 ⁻²	✗
PFA40-20	PFA40-20A	PFA40-20AR	20:1	83%	1.16 x 10 ⁻²	✗
PFA40-30	PFA40-30A	PFA40-30AR	30:1	76%	1.13 x 10 ⁻²	✗
PFA40-60	PFA40-60A	PFA40-60AR	60:1	65%	1.12 x 10 ⁻²	✓
PFA40-120	PFA40-120A	PFA40-120AR	120:1	41%	1.11 x 10 ⁻²	✓
PFA40-SP	PFA40-SPA	PFA40-SPAR	5:1-120:1	Special Ratios : Replace SP with required ratio		

Weight: 2.53 lb. Greased for Life: Shell Gadus S5 V42P 2.5.
F_a at 1000 Rpm: 66.14 lb. F_a at 1000 Rpm: 44.09 lb.

Tapped holes on input flange are not relative in position to the gearbox body and will alter from box to box. However, we can machine the tapped holes after assembly so they are relative in position to the gearbox body. This will affect delivery.

Motor Inputs also available.

Testing in your application is necessary.

You will need to assess duty cycles and confirm gearbox suitability with your own calculations. All figures listed are to be used for guidance only.

Output Torque lbf.in

Rpm	Reduction Ratio						
Input	10:1	12:1	15:1	20:1	30:1	60:1	120:1
3000	44.3	46.0	47.8	49.6	56.6	63.7	57.5
2000	48.7	51.3	54.9	58.4	64.6	70.8	63.7
1000	62.8	66.4	70.8	72.6	79.7	88.5	77.0
500	78.8	80.5	85.0	88.5	92.9	100.9	90.3
200	102.7	105.3	108.9	110.6	119.5	125.7	103.6
100	118.6	120.4	124.8	129.2	135.4	141.6	108.9
50	133.6	137.2	143.4	145.2	153.1	155.8	108.9
10	155.8	155.8	155.8	156.7	157.5	159.3	108.9

GEARBOXES

Precision Worm Gear Reducers

Flange Input 10.3 – 40 Nm **5:1 - 120:1**

e-cad
Drawings
Available

PF45

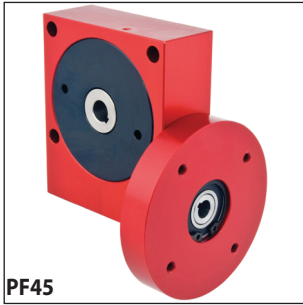

PF45

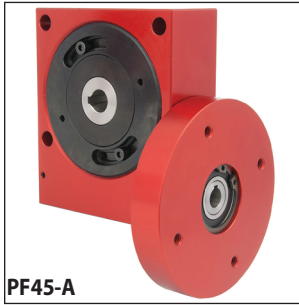

PF45-A

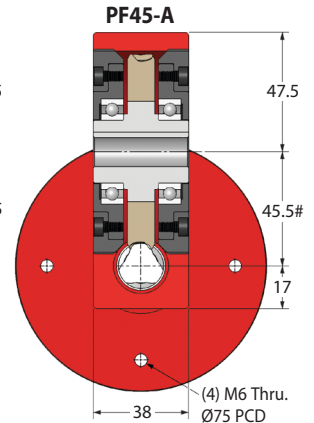
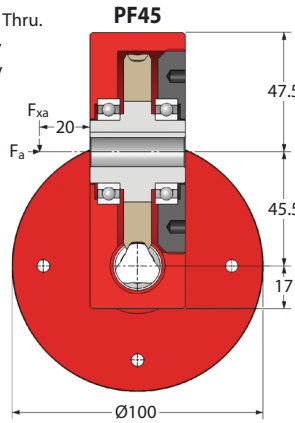
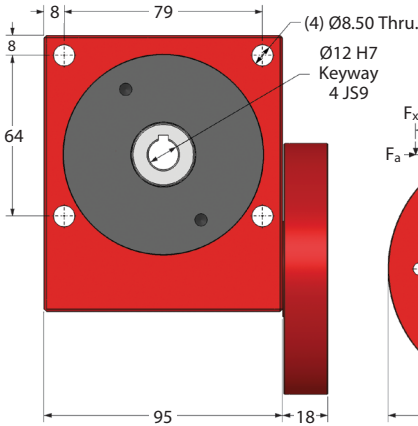
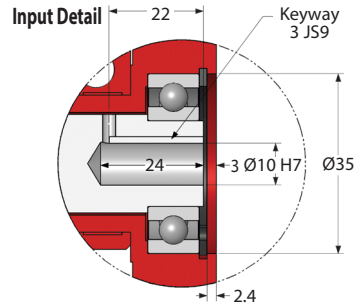

PF45A version (low backlash) output is on eccentric so centres will vary

Standard ≤30'	Part Number		Ratio	Efficiency at 1000 Rpm	Reflected Inertia at Input (kg.m ²)	Self Locking Output
Low Backlash ≤8'	Red. Backlash ≤4'					
PF45-10	PF45-10A	PF45-10AR	10:1	90%	7.34 x 10 ⁻⁶	✘
PF45-12	PF45-12A	PF45-12AR	12:1	89%	6.84 x 10 ⁻⁶	✘
PF45-15	PF45-15A	PF45-15AR	15:1	86%	6.43 x 10 ⁻⁶	✘
PF45-20	PF45-20A	PF45-20AR	20:1	85%	6.09 x 10 ⁻⁶	✘
PF45-30	PF45-30A	PF45-30AR	30:1	78%	5.86 x 10 ⁻⁶	✘
PF45-60	PF45-60A	PF45-60AR	60:1	67%	5.70 x 10 ⁻⁶	✔
PF45-120	PF45-120A	PF45-120AR	120:1	47%	5.66 x 10 ⁻⁶	✔
PF45-SP	PF45-SPA	PF45-SPAR	5:1-120:1	Special Ratios : Replace SP with required ratio		

Accessories

P45-X

Single Output Shafts

P45-DX

Double Output Shafts

KK4-25

Output Key

Weight: 1.15 kg. Greased for Life: Shell Gadus S5 V42P 2.5.

F_{ax} at 1000 Rpm: 45 kg. F_a at 1000 Rpm: 30 kg.

Tapped holes on input flange are not relative in position to the gearbox body and will alter from box to box. However, we can machine the tapped holes after assembly so they are relative in position to the gearbox body. This will affect delivery.

Motor Inputs also available.

Testing in your application is necessary.

You will need to assess duty cycles and confirm gearbox suitability with your own calculations.

All figures listed are to be used for guidance only.

Output Torque Nm

Rpm	Reduction Ratio						
Input	10:1	12:1	15:1	20:1	30:1	60:1	120:1
3000	10.3	10.8	11.3	12.2	13.2	14.7	10.8
2000	11.7	12.2	12.7	13.2	14.7	17.1	12.7
1000	14.7	15.2	16.2	17.1	18.1	20.6	14.3
500	19.1	19.6	20.6	21.6	22.5	24.5	17.5
200	24.4	25.5	26.4	27.0	28.9	30.0	20.6
100	28.3	28.9	29.4	30.3	31.8	33.8	22.8
50	32.3	32.8	33.8	34.3	34.5	35.2	23.0
10	39.9	39.9	39.9	40.0	40.0	40.0	23.0

sales@ondrives.us
www.ondrives.us

516-771-6777
516-771-6444

ondrives.US Corp.

GEARBOXES

Precision Worm Gear Reducers

Flange Input 13.4 – 57 Nm **5:1 - 120:1**

e-cad
Drawings
Available

PF55

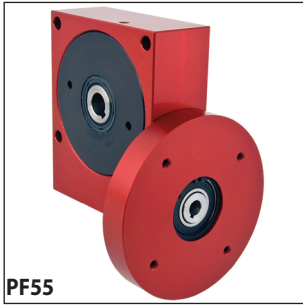

PF55

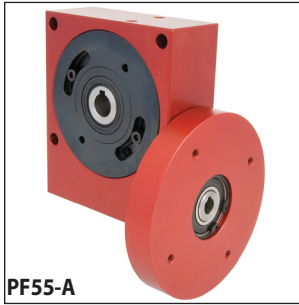

PF55-A

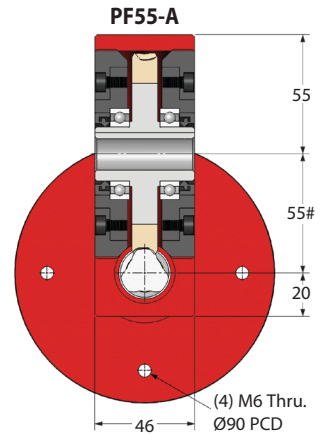
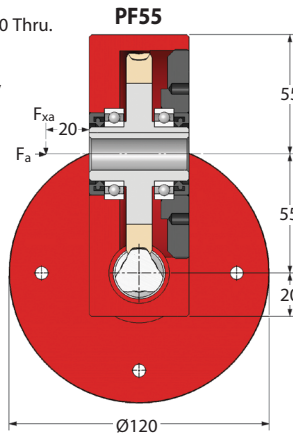
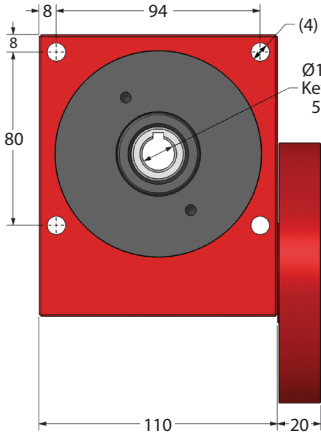
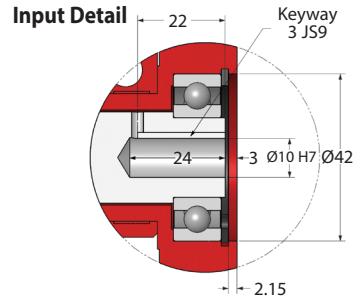

PF55A version (low backlash) output is on eccentric so centres will vary

Standard ≤30'	Part Number Low Backlash ≤8'	Red. Backlash ≤4'	Ratio	Efficiency at 1000 Rpm	Reflected Inertia at Input (kg.m ²)	Self Locking Output
PF55-10	PF55-10A	PF55-10AR	10:1	89%	1.96 x 10 ⁻⁵	✘
PF55-12	PF55-12A	PF55-12AR	12:1	88%	1.84 x 10 ⁻⁵	✘
PF55-15	PF55-15A	PF55-15AR	15:1	86%	1.74 x 10 ⁻⁵	✘
PF55-20	PF55-20A	PF55-20AR	20:1	84%	1.67 x 10 ⁻⁵	✘
PF55-30	PF55-30A	PF55-30AR	30:1	78%	1.62 x 10 ⁻⁵	✘
PF55-60	PF55-60A	PF55-60AR	60:1	69%	1.58 x 10 ⁻⁵	✓
PF55-120	PF55-120A	PF55-120AR	120:1	47%	1.57 x 10 ⁻⁵	✓
PF55-SP	PF55-SPA	PF55-SPAR	5:1-120:1	Special Ratios : Replace SP with required ratio		

Accessories

P55-X

Single Output Shafts

P55-DX

Double Output Shafts

KK5-30

Output Key

Weight: 3.04 kg. Greased for Life: Shell Gadus S5 V42P 2.5.

F_a at 1000 Rpm: 60 kg. F_a at 1000 Rpm: 40 kg.

Tapped holes on input flange are not relative in position to the gearbox body and will alter from box to box. However, we can machine the tapped holes after assembly so they are relative in position to the gearbox body. This will affect delivery.

Motor Inputs also available.

Testing in your application is necessary.

You will need to assess duty cycles and confirm gearbox suitability with your own calculations.

All figures listed are to be used for guidance only.

Output Torque Nm

Rpm Input	Reduction Ratio						
	10:1	12:1	15:1	20:1	30:1	60:1	120:1
3000	13.4	14.0	14.8	16.2	17.6	20.4	18.0
2000	16.2	16.9	18.3	19.1	20.4	23.9	20.0
1000	21.1	22.5	23.2	24.6	25.3	28.8	25.0
500	27.4	28.1	28.8	30.2	31.6	35.1	30.0
200	34.4	35.1	36.5	37.9	39.3	42.1	36.0
100	40.0	41.4	42.1	42.8	44.9	46.3	38.0
50	45.6	46.3	47.7	48.4	49.8	50.5	38.0
10	56.8	56.8	56.8	57.0	57.0	57.0	38.0

sales@ondrives.us
www.ondrives.us

516-771-6777
516-771-6444

ondrives .US Corp.

GEARBOXES

Precision Worm Gear Reducers

Flange Input 30 – 118 Nm **5:1 - 120:1**

e-cad
Drawings
Available

PF60

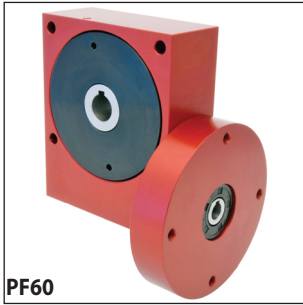

PF60



PF60-A

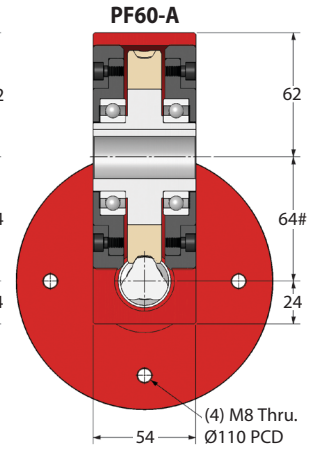
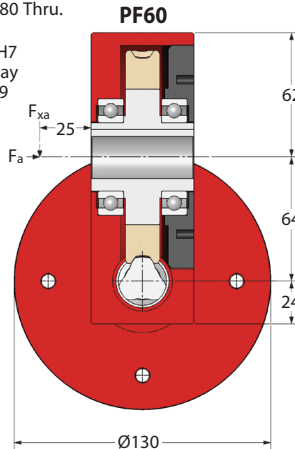
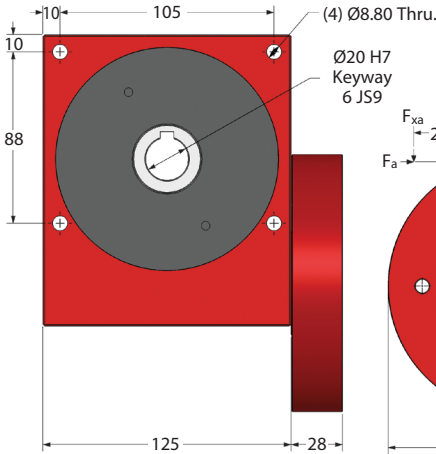
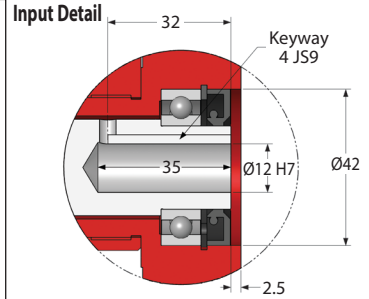

PF60A version (low backlash) output is on eccentric so centres will vary

Standard ≤30'	Part Number Low Backlash ≤8'	Red. Backlash ≤4'	Ratio	Efficiency at 1000 Rpm	Reflected Inertia at Input (kg.m ²)	Self Locking Output
PF60-10	PF60-10A	PF60-10AR	10:1	90%	3.80 x 10 ⁻⁵	✘
PF60-12	PF60-12A	PF60-12AR	12:1	89%	3.68 x 10 ⁻⁵	✘
PF60-15	PF60-15A	PF60-15AR	15:1	85%	3.14 x 10 ⁻⁵	✘
PF60-20	PF60-20A	PF60-20AR	20:1	85%	3.10 x 10 ⁻⁵	✘
PF60-30	PF60-30A	PF60-30AR	30:1	78%	2.88 x 10 ⁻⁵	✘
PF60-60	PF60-60A	PF60-60AR	60:1	68%	2.82 x 10 ⁻⁵	✓
PF60-120	PF60-120A	PF60-120AR	120:1	45%	2.79 x 10 ⁻⁵	✓
PF60-SP	PF60-SPA	PF60-SPAR	5:1-120:1	Special Ratios : Replace SP with required ratio		

Accessories

P60-X

Single Output Shafts

P60-DX

Double Output Shafts

KK6-30

Output Key

Weight: 5.10 kg. Greased for Life: Shell Gadus S5 V42P 2.5.

F_{ax} at 1000 Rpm: 70 kg. F_a at 1000 Rpm: 50 kg.

Tapped holes on input flange are not relative in position to the gearbox body and will alter from box to box. However, we can machine the tapped holes after assembly so they are relative in position to the gearbox body. This will affect delivery.

Motor Inputs also available.

Testing in your application is necessary.

You will need to assess duty cycles and confirm gearbox suitability with your own calculations.

All figures listed are to be used for guidance only.

Output Torque Nm

Rpm	Reduction Ratio						
Input	10:1	12:1	15:1	20:1	30:1	60:1	120:1
3000	30	31	33	35	38	44	27
2000	33	36	39	41	44	50	32
1000	45	47	50	54	58	64	39
500	58	60	62	65	69	73	47
200	77	78	80	84	88	94	55
100	88	89	91	94	97	105	61
50	100	102	104	105	107	110	66
10	113	114	115	116	116	118	66

sales@ondrives.us
www.ondrives.us

516-771-6777
516-771-6444

ondrives.US Corp.

GEARBOXES

Precision Worm Gear Reducers

Flange Input 38 – 164 Nm **5:1 - 120:1**

e-cad
Drawings
Available

PF70

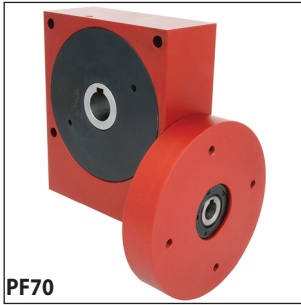

PF70

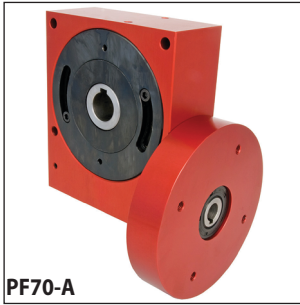

PF70-A

Input Detail

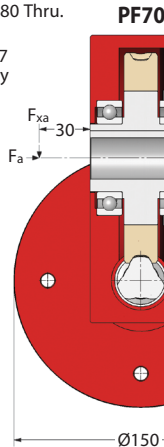
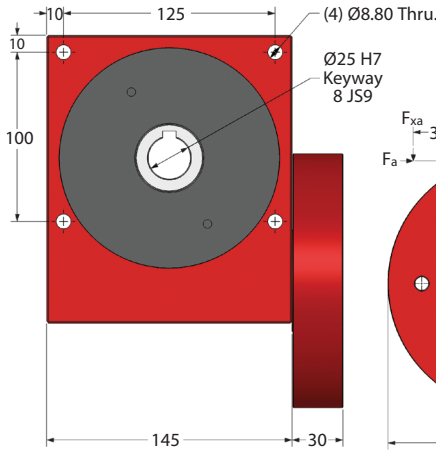
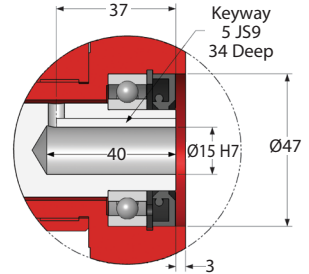

PF70

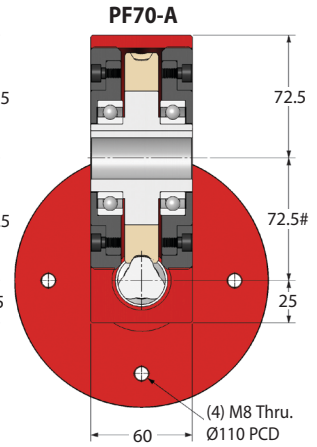

PF70-A

PF70A version (low backlash) output is on eccentric so centres will vary

Standard ≤30'	Part Number Low Backlash ≤8'	Red. Backlash ≤4'	Ratio	Efficiency at 1000 Rpm	Reflected Inertia at Input (kg.m ²)	Self Locking Output
PF70-10	PF70-10A	PF70-10AR	10:1	90%	4.81 x 10 ⁻⁵	✘
PF70-12	PF70-12A	PF70-12AR	12:1	89%	4.19 x 10 ⁻⁵	✘
PF70-15	PF70-15A	PF70-15AR	15:1	86%	3.70 x 10 ⁻⁵	✘
PF70-20	PF70-20A	PF70-20AR	20:1	85%	3.28 x 10 ⁻⁵	✘
PF70-30	PF70-30A	PF70-30AR	30:1	78%	3.00 x 10 ⁻⁵	✘
PF70-60	PF70-60A	PF70-60AR	60:1	67%	2.89 x 10 ⁻⁵	✓
PF70-120	PF70-120A	PF70-120AR	120:1	50%	2.76 x 10 ⁻⁵	✓
PF70-SP	PF70-SPA	PF70-SPAR	5:1-120:1	Special Ratios : Replace SP with required ratio		

Accessories

P70-X

Single Output Shafts

P70-DX

Double Output Shafts

KK8-7-40

Output Key

Weight: 7.90 kg. Greased for Life: Shell Gadus S5 V42P 2.5.

F_a at 1000 Rpm: 80 kg. F_x at 1000 Rpm: 60 kg.

Tapped holes on input flange are not relative in position to the gearbox body and will alter from box to box. However, we can machine the tapped holes after assembly so they are relative in position to the gearbox body. This will affect delivery.

Motor Inputs also available.

Testing in your application is necessary.

You will need to assess duty cycles and confirm gearbox suitability with your own calculations.

All figures listed are to be used for guidance only.

Output Torque Nm

Rpm Input	Reduction Ratio						
	10:1	12:1	15:1	20:1	30:1	60:1	120:1
3000	38	40	42	45	50	56	38
2000	47	49	53	55	61	69	46
1000	61	65	67	71	73	83	55
500	77	81	83	87	91	100	66
200	99	101	105	107	113	121	77
100	115	119	121	123	129	133	86
50	129	133	137	139	144	146	90
10	160	160	160	164	164	164	90