

## Zero Backlash Universal Joints

Single Delrin™ with extended Brass inserts

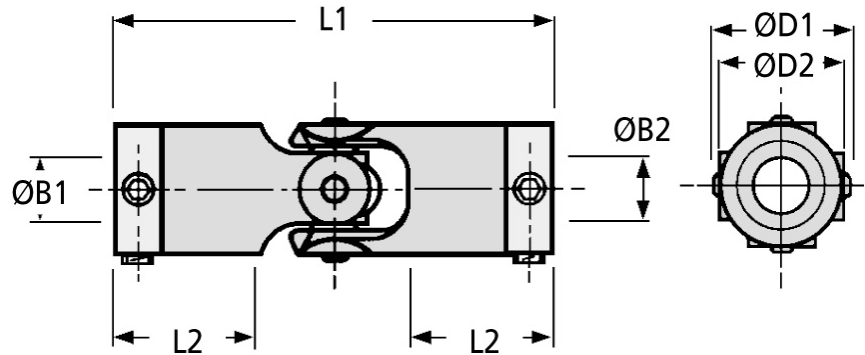

Part Number	ØB1	ØB2	Max Bore	ØD1	ØD1	L1	L2	Thread	Moment of Inertia (kgm <sup>2</sup> x 10 <sup>-8</sup> )	Static Break Torque (N-m)	Peak Torque (N)	Max End-loading	Max Angular	Weight (g)
103.06.1414	3mm	3mm	1/8"	0.28	0.25	1.07	0.37	M3	1.1	0.45	0.11	18	45°	3.1
103.06.1616	1/8"	1/8"	1/8"	0.28	0.25	1.07	0.37	M3	1.1	0.45	0.11	18	45°	3.1
103.09.1414	3mm	3mm	5mm	0.44	0.37	1.48	0.52	M3	13.5	1.9	0.36	38	45°	9.3
103.09.1616	1/8"	1/8"	5mm	0.44	0.37	1.48	0.52	M3	13.5	1.9	0.36	38	45°	9.3
103.09.1818	4mm	4mm	5mm	0.44	0.37	1.48	0.52	M3	13.5	1.9	0.36	38	45°	9.3
103.09.1919	3/16"	3/16"	5mm	0.44	0.37	1.48	0.52	M3	13.5	1.9	0.36	38	45°	9.3
103.09.2020	5mm	5mm	5mm	0.44	0.37	1.48	0.52	M3	13.5	1.9	0.36	38	45°	9.3
103.13.1818	4mm	4mm	1/4"	0.56	0.5	1.82	0.62	M3	44.6	4.5	0.85	67	45°	17.7
103.13.1919	3/16"	3/16"	1/4"	0.56	0.5	1.82	0.62	M3	44.6	4.5	0.85	67	45°	17.7
103.13.2020	5mm	5mm	1/4"	0.56	0.5	1.82	0.62	M3	44.6	4.5	0.85	67	45°	17.7
103.13.2222	6mm	6mm	1/4"	0.56	0.5	1.82	0.62	M3	44.6	4.5	0.85	67	45°	17.7
103.13.2424	1/4"	1/4"	1/4"	0.56	0.5	1.82	0.62	M3	44.6	4.5	0.85	67	45°	17.7
103.16.2222	6mm	6mm	10mm	0.69	0.63	2.66	0.88	M4	136	6.8	1.6	98	45°	35
103.16.2424	1/4"	1/4"	10mm	0.69	0.63	2.66	0.88	M4	136	6.8	1.6	98	45°	35
103.16.2828	8mm	8mm	10mm	0.69	0.63	2.66	0.88	M4	136	6.8	1.6	98	45°	35
103.16.3131	3/8"	3/8"	10mm	0.69	0.63	2.66	0.88	M4	136	6.8	1.6	98	45°	35
103.16.3232	10mm	10mm	10mm	0.69	0.63	2.66	0.88	M4	136	6.8	1.6	98	45°	35

**Materials**

Cross Piece and Inserts: Brass CZ121/C37710  
Body: Black Acetal/Delrin™

**Performance**

Maximum speed: 1000 rpm  
Temperature range: -20C to +60C  
Backlash free up to 10<sup>8</sup> turns

Peak torque values apply when working angle is zero. Adjusted torque takes account of the dynamic loading of the bearings. To find adjusted torque, determine application speed, torque and operating angle. Then (a) multiple speed x working angle, (b) subtract result from 10,000, (c) divide by 10,000, (d) apply result to application torque.

For example: Speed = 400 rpm, Torque, 0.1Nm, Working angle 20°

(a) 400 rpm x 20° = 8,000 (b) 10,000 - 8,000 = 2,000 (c) 10,000/2,000 = 5 (d) 5 x 0.1 Nm = 0.5 Nm  
Select a joint where the peak torque exceeds 0.5 Nm ie: Size 13 or larger.

**Note:** Speed x working angle must be less than 10,000 to be within capacity

## Zero Backlash Universal Joints

Double Delrin™ with extended Brass inserts

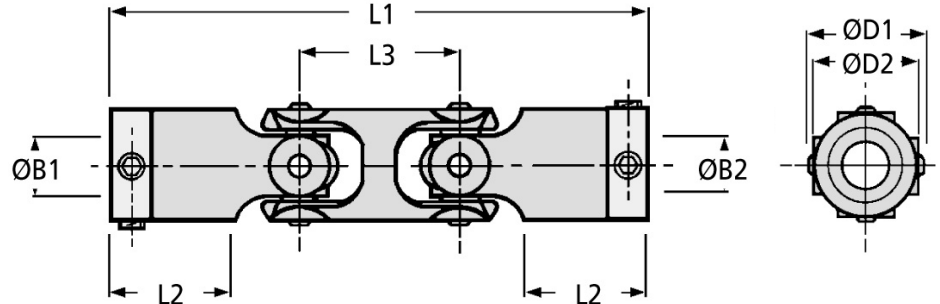

Part Number	ØB1	ØB2	Max Bore	ØD1	ØD1	L1	L2	L3	Thread	Moment of Inertia (kgm <sup>2</sup> x 10 <sup>-8</sup> )	Static Break Torque (N-m)	Peak Torque (N-m)	Max Radial Offset	Weight (g)
111.06.1414	3mm	3mm	1/8"	0.28	0.25	1.39	0.37	0.32	M3	1.3	0.34	0.08	90°	3.5
111.06.1616	1/8"	1/8"	1/8"	0.28	0.25	1.39	0.37	0.32	M3	1.3	0.34	0.08	90°	3.5
111.09.1414	3mm	3mm	5mm	0.44	0.37	2.0	0.52	0.52	M3	15.3	1.9	0.16	90°	11.1
111.09.1616	1/8"	1/8"	5mm	0.44	0.37	2.0	0.52	0.52	M3	15.3	1.9	0.16	90°	11.1
111.09.1818	4mm	4mm	5mm	0.44	0.37	2.0	0.52	0.52	M3	15.3	1.9	0.16	90°	11.1
111.09.1919	3/16"	3/16"	5mm	0.44	0.37	2.0	0.52	0.52	M3	15.3	1.9	0.16	90°	11.1
111.09.2020	5mm	5mm	5mm	0.44	0.37	2.0	0.52	0.52	M3	15.3	1.9	0.16	90°	11.1
111.13.1818	4mm	4mm	1/4"	0.56	0.5	2.44	0.62	0.63	M3	50.4	3.4	0.59	90°	21.6
111.13.1919	3/16"	3/16"	1/4"	0.56	0.5	2.44	0.62	0.63	M3	50.4	3.4	0.59	90°	21.6
111.13.2020	5mm	5mm	1/4"	0.56	0.5	2.44	0.62	0.63	M3	50.4	3.4	0.59	90°	21.6
111.13.2222	6mm	6mm	1/4"	0.56	0.5	2.44	0.62	0.63	M3	50.4	3.4	0.59	90°	21.6
111.13.2424	1/4"	1/4"	1/4"	0.56	0.5	2.44	0.62	0.63	M3	50.4	3.4	0.59	90°	21.6
111.16.2222	6mm	6mm	10mm	0.69	0.63	3.54	0.88	0.87	M4	178	6.8	1.3	90°	42.4
111.16.2424	1/4"	1/4"	10mm	0.69	0.63	3.54	0.88	0.87	M4	178	6.8	1.3	90°	42.4
111.16.2828	8mm	8mm	10mm	0.69	0.63	3.54	0.88	0.87	M4	178	6.8	1.3	90°	42.4
111.16.3131	3/8"	3/8"	10mm	0.69	0.63	3.54	0.88	0.87	M4	178	6.8	1.3	90°	42.4
111.16.3232	10mm	10mm	10mm	0.69	0.63	3.54	0.88	0.87	M4	178	6.8	1.3	90°	42.4

**Materials**

Cross Piece and Inserts: Brass CZ121/C37710  
Body: Black Acetal/Delrin™

**Performance**

Maximum speed: 1000 rpm  
Temperature range: -20C to +60C  
Backlash free up to 10<sup>8</sup> turns

Peak torque values apply when working angle is zero. Adjusted torque takes account of the dynamic loading of the bearings. To find adjusted torque, determine application speed, torque and operating angle. Then (a) multiple speed x working angle, (b) subtract result from 10,000, (c) divide by 10,000, (d) apply result to application torque.

For example: Speed = 400 rpm, Torque, 0.1Nm, Working angle 20°

(a) 400 rpm x 20° = 8,000 (b) 10,000 - 8,000 = 2,000 (c) 10,000/2,000 = 5 (d) 5 x 0.1 Nm = 0.5 Nm  
Select a joint where the peak torque exceeds 0.5 Nm ie: Size 13 or larger.

**Note:** Speed x working angle must be less than 10,000 to be within capacity