

XGT

COUPLINGS

XGT

Vibration Absorption Flexible Coupling

Backlash Free, Cap Screw Fixing : 1.1 - 70Nm, 4 - 28mm Bores

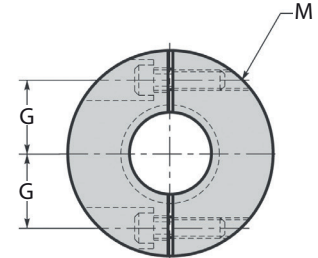
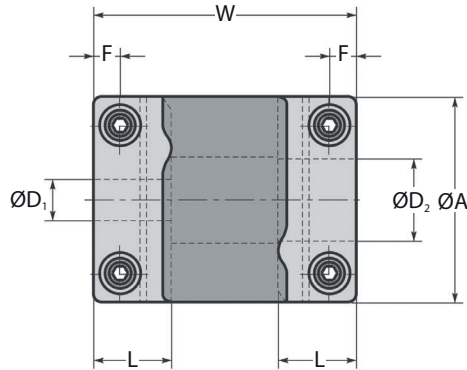

Part Number	Max RPM	Moment of Inertia [†] kg-m ²	Static Torsional Stiffness Nm/rad	Max. Parallel Offset	Max. Working Angle	Max. Axial Play (mm)	Mass [†] g
XGT-15C	42,000	2.7 x 10 ⁻⁷	43	0.15	1.5°	±0.2	8
XGT-19C	33,000	8.4 x 10 ⁻⁷	88	0.15	1.5°	±0.2	14
XGT-25C	25,000	3.0 x 10 ⁻⁶	140	0.15	1.5°	±0.3	28
XGT-30C	21,000	6.9 x 10 ⁻⁶	220	0.20	1.5°	±0.3	45
XGT-34C	18,000	1.3 x 10 ⁻⁵	390	0.20	1.5°	±0.3	65
XGT-39C	16,000	2.7 x 10 ⁻⁵	520	0.20	1.5°	±0.3	98
XGT-44C	14,000	4.2 x 10 ⁻⁵	640	0.20	1.5°	±0.3	136
XGT-56C	11,000	1.4 x 10 ⁻⁴	1500	0.20	1.5°	±0.3	276

† Based on maximum bore dimensions.

*More Sizes available on our website

Part Number	Standard Bores ØD ₁ , ØD ₂	Min Bores ØD ₁ , ØD ₂	Max Bores ØD ₁ , ØD ₂	A	L	W	F	G	M	Wrench Torque Nm	Rated [‡] Torque Nm	Max [‡] Torque Nm
XGT-15C	4 x 4	4	6	15	6.5	23	2.15	5.00	M1.6	0.25	01.1	02.2
XGT-19C	5 x 5	5	8	19	7.7	26	2.65	6.50	M2	0.50	02.1	04.2
XGT-25C	6 x 6	6	12	25	9.5	32	3.25	9.00	M2.5	1.00	04.0	08.0
XGT-30C	8 x 8	8	15	30	11.0	36	4.00	11.00	M3	1.50	06.3	12.6
XGT-34C	10 x 10	10	16	34	12.0	38	4.00	12.25	M3	1.50	08.0	16.0
XGT-39C	12 x 12	12	20	39	15.5	48	4.50	14.50	M4	2.50	13.5	27.0
XGT-44C	14 x 14	14	22	44	15.0	48	4.75	16.00	M4	2.50	18.0	36.0
XGT-56C	15 x 15	15	28	56	19.5	60	5.50	20.00	M5	7.00	35.0	70.0

‡ Adjustment of rated and maximum torque specifications for load fluctuations is not required.
However, if operating temperature exceeds 30°C, please adjust rated torque and maximum torque as follows:

Air Temperature:	-20°C to +30°C	+30°C to +40°C	+40°C to +60°C	+60°C to +80°C
Temperature Correction Factor:	1.00	0.80	0.70	0.55

Materials

Hub: Aluminium A2017.
Anti-vibration Rubber: HNBR.
Cap Screw: Steel SCM435 Black Oxide Coating.

Performance

Operating Temperature Range: -20°C to +80°C Approx.
Volume Resistance: 10¹²-10¹³ Ωm.

Extras

Stainless Steel Capscrews. Bore and keyway modifications available on request.

Other Info

Excellent resistance to aging, weathering, ozone, light oil, alcohol, water, strong alkali and low concentration organic acid.
Excellent vibration absorption and electrical insulation.
High torque single piece structure with anti-vibration rubber moulded between two hubs. For use with servo motors and stepper motors.
Identical clockwise and counter-clockwise rotational characteristics.
Recommended tolerance for shaft diameters is h6 and h7.
Split coupling for easy attachment and removal.

ondrives.us

1-888-260-7466
516-771-6444

sales@ondrivesus.com
www.ondrivesus.com