

GA

SHAFTS

Precision Ground Shafting

Inch - 12L14 Steel

GA

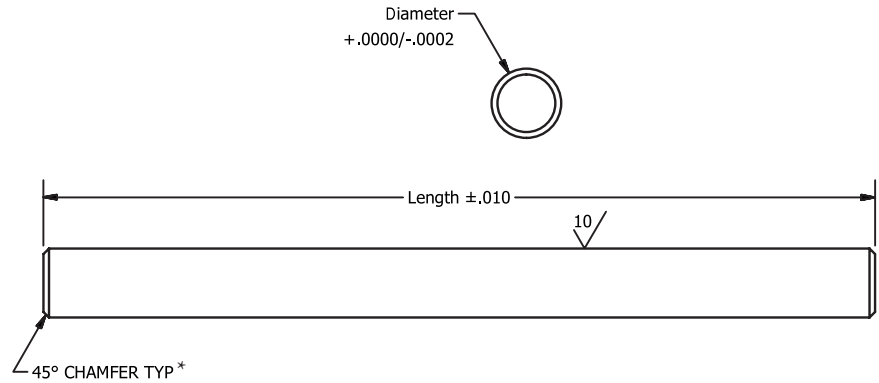
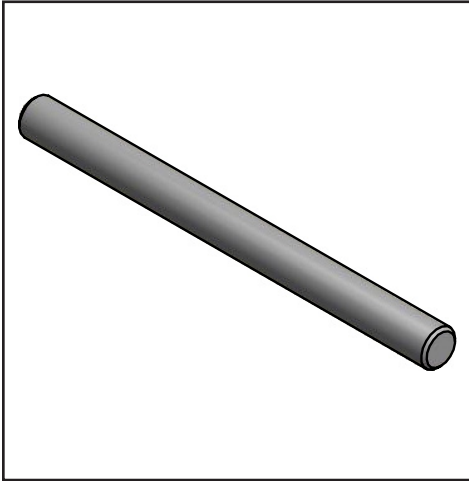

Surface Finish 10µin

Part Number	Ref.	+0.0000 / -0.0002 Diameter	+/- .010 Length
GA0312-30	1/32"	0.0312	3.00
GA0312-40	1/32"	0.0312	4.00
GA0312-50	1/32"	0.0312	5.00
GA0312-60	1/32"	0.0312	6.00
GA0312-70	1/32"	0.0312	7.00
GA0312-80	1/32"	0.0312	8.00
GA0312-90	1/32"	0.0312	9.00
GA0312-100	1/32"	0.0312	10.00
GA0312-120	1/32"	0.0312	12.00
GA0312-180	1/32"	0.0312	18.00
GA0625-30	1/16"	0.0625	3.00
GA0625-40	1/16"	0.0625	4.00
GA0625-50	1/16"	0.0625	5.00
GA0625-60	1/16"	0.0625	6.00
GA0625-70	1/16"	0.0625	7.00
GA0625-80	1/16"	0.0625	8.00
GA0625-90	1/16"	0.0625	9.00
GA0625-100	1/16"	0.0625	10.00
GA0625-120	1/16"	0.0625	12.00
GA0625-180	1/16"	0.0625	18.00
GA0625-240	1/16"	0.0625	24.00
GA0625-360	1/16"	0.0625	36.00

Part Number	Ref.	+0.0000 / -0.0002 Diameter	+/- .010 Length
GA1250-30	1/8"	0.1250	3.00
GA1250-40	1/8"	0.1250	4.00
GA1250-50	1/8"	0.1250	5.00
GA1250-60	1/8"	0.1250	6.00
GA1250-70	1/8"	0.1250	7.00
GA1250-80	1/8"	0.1250	8.00
GA1250-90	1/8"	0.1250	9.00
GA1250-100	1/8"	0.1250	10.00
GA1250-120	1/8"	0.1250	12.00
GA1250-180	1/8"	0.1250	18.00
GA1250-240	1/8"	0.1250	24.00
GA1250-360	1/8"	0.1250	36.00
GA1875-30	3/16"	0.1875	3.00
GA1875-40	3/16"	0.1875	4.00
GA1875-50	3/16"	0.1875	5.00
GA1875-60	3/16"	0.1875	6.00
GA1875-70	3/16"	0.1875	7.00
GA1875-80	3/16"	0.1875	8.00
GA1875-90	3/16"	0.1875	9.00
GA1875-100	3/16"	0.1875	10.00
GA1875-120	3/16"	0.1875	12.00
GA1875-180	3/16"	0.1875	18.00
GA1875-240	3/16"	0.1875	24.00
GA1875-360	3/16"	0.1875	36.00

Part Number	Ref.	+0.0000 / -0.0002 Diameter	+/- .010 Length
GA2500-30	1/4"	0.2500	3.00
GA2500-40	1/4"	0.2500	4.00
GA2500-50	1/4"	0.2500	5.00
GA2500-60	1/4"	0.2500	6.00
GA2500-70	1/4"	0.2500	7.00
GA2500-80	1/4"	0.2500	8.00
GA2500-90	1/4"	0.2500	9.00
GA2500-100	1/4"	0.2500	10.00
GA2500-120	1/4"	0.2500	12.00
GA2500-180	1/4"	0.2500	18.00
GA2500-240	1/4"	0.2500	24.00
GA2500-360	1/4"	0.2500	36.00
GA2500-480	1/4"	0.2500	48.00
GA3125-30	5/16"	0.3125	3.00
GA3125-40	5/16"	0.3125	4.00
GA3125-50	5/16"	0.3125	5.00
GA3125-60	5/16"	0.3125	6.00
GA3125-70	5/16"	0.3125	7.00
GA3125-80	5/16"	0.3125	8.00
GA3125-90	5/16"	0.3125	9.00
GA3125-100	5/16"	0.3125	10.00
GA3125-120	5/16"	0.3125	12.00
GA3125-180	5/16"	0.3125	18.00
GA3125-240	5/16"	0.3125	24.00
GA3125-360	5/16"	0.3125	36.00

Rockwell B83

*Chamfered both ends

Precision ground 12L14 Steel
Diameters from .0312 to .3125
Lengths from 3" to 36"

Straightness:

1/8" to 1/4" Diameter: 0.0004in./in.

Over 1/4" Diameter: 0.0006in./in.

***Chamfer:** 1/8" Diameter and larger. Break edge below 1/8" Diameter

From stock delivery

Other materials available from stock:

303, 316, 17-4 PH, C1060, 440C

Special sizes and other materials are available, please ask

Customizing: grooves, journals, flats, drill holes, thread + tapped holes, chamfers, special diameters, special lengths

ondrives.us

☎ 1-888-260-7466

📄 516-771-6444

💻 sales@ondrivesus.com

🌐 www.ondrivesus.com

GA

SHAFTS

GA

12L14 Precision Ground Shafting

Inch - 1/8" to 1-1/4" Diameters
Rough Cut Ends

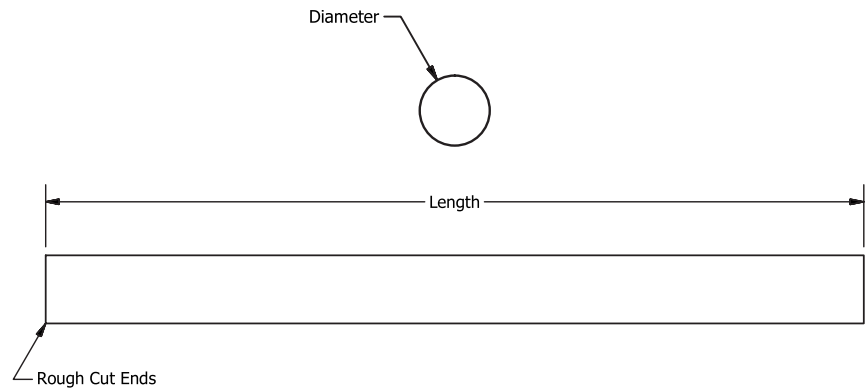
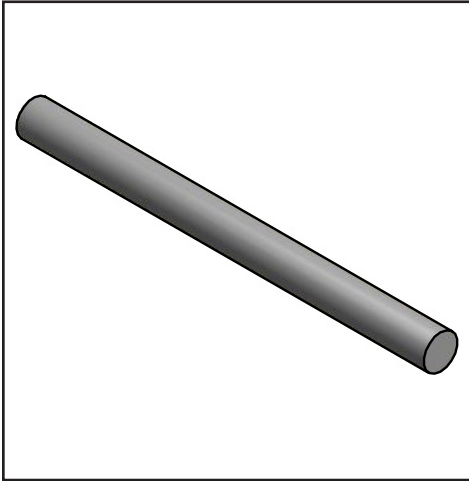

Toleranced for use with Ball Bearings

Inch Shafts			
Part Number	Nominal Diameter	Diameter	± .125" Length
GA1247-350SC	1/8"	0.1247	35"
GA1872-350SC	3/16"	0.1872	35"
GA2497-350SC	1/4"	0.2497	35"
GA3122-350SC	5/16"	0.3122	35"
GA3747-350SC	3/8"	0.3747	35"
GA4997-350SC	1/2"	0.4997	35"
GA6247-350SC	5/8"	0.6247	35"
GA7497-350SC	3/4"	0.7497	35"
GA9997-350SC	1"	0.9997	35"
GA12497-350SC	1-1/4"	1.2497	35"

Specifications:

Material: 12L14 Steel

Ideal use for:

Ball bearings, pulleys, couplings, gears, any rotating component

Straightness:

1/8" to 1/4" Diameter: 0.0004in./in.

Over 1/4" Diameter: 0.0006in./in.

From stock delivery

Special sizes and other materials are available, please ask
Customizing is available: grooves, journals, flats, drill holes, thread + tapped holes, chamfers, special diameters, special lengths

GAM

SHAFTS

GAM

12L14 Steel Precision Ground Shafting

Metric - 3mm to 32mm Diameters
Rough Cut Ends

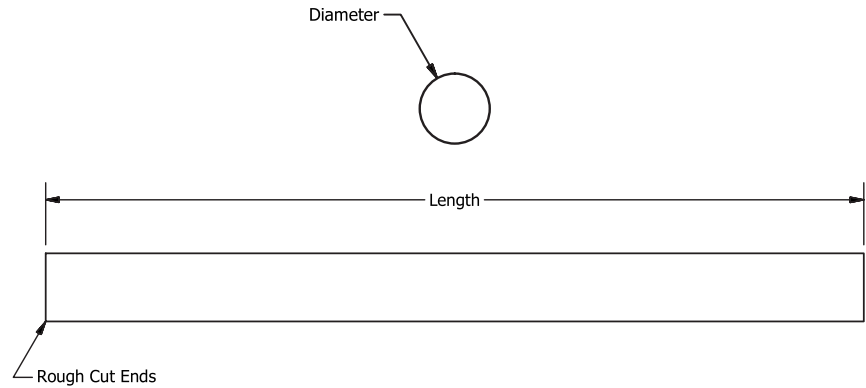
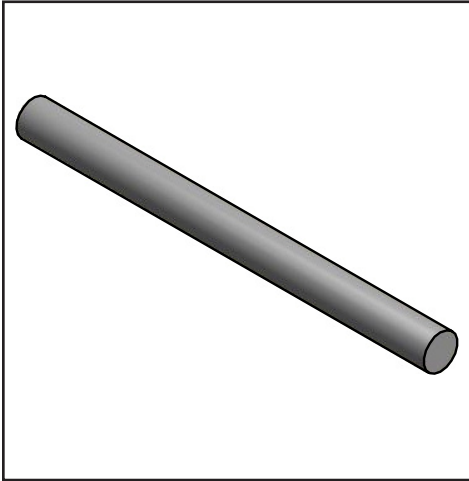

*Toleranced for use with Ball Bearings

Metric Shafts				
Part Number	Nominal Diameter	Diameter	Diameter Tolerance	±.3mm Length
GAM2993-900SC	3mm	2.993	-.005mm	900mm
GAM3993-900SC	4mm	3.993	-.005mm	900mm
GAM5993-900SC	6mm	5.993	-.005mm	900mm
GAM7993-900SC	8mm	7.993	-.005mm	900mm
GAM9993-900SC	10mm	9.993	-.005mm	900mm
GAM11993-900SC	12mm	11.993	-.010mm	900mm
GAM15993-900SC	16mm	15.993	-.010mm	900mm
GAM19993-900SC	20mm	19.993	-.010mm	900mm
GAM24993-900SC	25mm	24.993	-.010mm	900mm
GAM31993-900SC	32mm	31.993	-.010mm	900mm

Specifications:

Material: 12L14 Steel

Ideal use for:

Ball bearings, pulleys, couplings, gears, any rotating component

Straightness:

3mm to 6mm Diameter: 0.004mm/mm

Over 6mm Diameter: 0.006mm/mm

From stock delivery

Special sizes and other materials are available, please ask

Customizing is available: grooves, journals, flats, drill holes, thread + tapped holes, chamfers, special diameters, special lengths