

**BLH60  
BLHT60**

# GEARBOXES

**BLH60  
BLHT60**

## Spiral Bevel & Spiral Bevel Tee Heavy Duty Gearbox

Hardened Spiral Bevels 19 – 70 Nm **1:1 - 2:1**  
Metric Shaft Diameters



**BLH60**



**BLHT60**

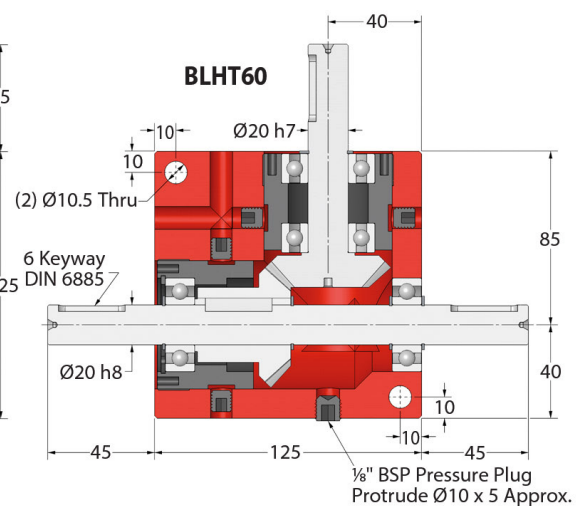
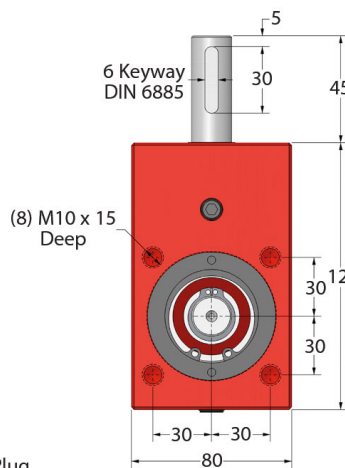
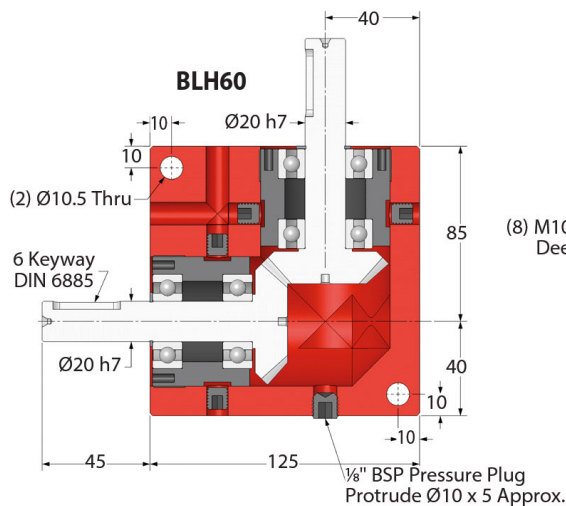

Part Number			Ratio	Efficiency at 1000 RPM	Reflected Inertia at Input (kg.m <sup>2</sup> )
Standard ≈1°	Low Standard ≤30'	Red. Standard ≤10'			
<b>BLH60-1</b>	<b>BLH60-1A</b>	<b>BLH60-1AR</b>	1:1	88%	1.99 x 10 <sup>-4</sup>
<b>BLH60-2</b>	<b>BLH60-2A</b>	<b>BLH60-2AR</b>	2:1	88%	3.87 x 10 <sup>-5</sup>
<b>BLHT60-1</b>	<b>BLHT60-1A</b>	<b>BLHT60-1AR</b>	1:1	88%	1.99 x 10 <sup>-4</sup>
<b>BLHT60-2</b>	<b>BLHT60-2A</b>	<b>BLHT60-2AR</b>	2:1	88%	3.87 x 10 <sup>-5</sup>

Weight: BLH: 4.50 kg, BLHT: 4.75 kg.

Output Backlash: ≈1°.

Max. Input Speed: 3,000 Rpm.

Greased for Life: Shell Gadus S2 V220AD 2.

Input/Output Key: KK6-30.

Testing in your application is necessary. You will need to assess duty cycles and confirm gearbox suitability with your own calculations. All figures listed are to be used for guidance only.

### Output Torque Nm

RPM Input	Reduction Ratio	
	1:1	2:1
<b>3000</b>	26.0	19.0
<b>2000</b>	30.0	22.0
<b>1750</b>	31.3	22.8
<b>1000</b>	35.0	25.0
<b>500</b>	40.0	29.0
<b>100</b>	53.0	38.0
<b>50</b>	57.0	43.0
<b>10</b>	70.0	52.0