

BLHA30  
BLHTA30

# GEARBOXES

BLHA30  
BLHTA30

## Spiral Bevel & Spiral Bevel Tee Heavy Duty Gearbox

Hardened Spiral Bevels 11.7 – 38.9 lbf.in 1:1 - 2:1  
Inch Shaft Diameters

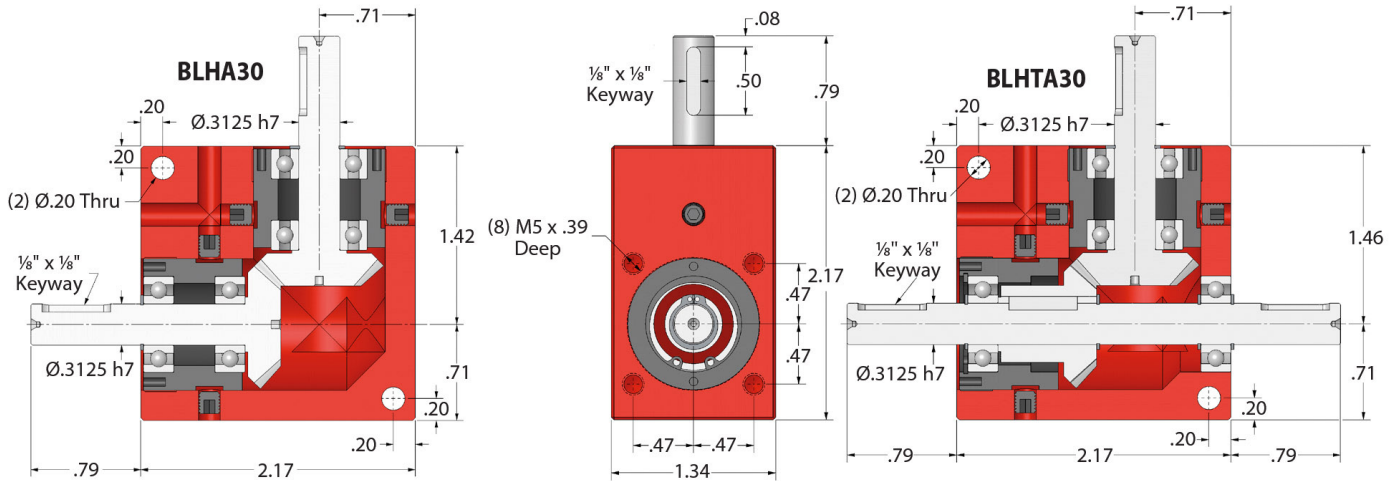
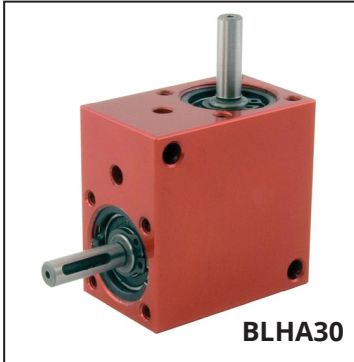

Part Number	Ratio	Efficiency at 1000 Rpm	Reflected Inertia at Input (lb.in <sup>2</sup> )
BLHA30-1 BLHTA30-1	1:1	88%	7.48 x 10 <sup>-3</sup>
BLHA30-2 BLHTA30-2	2:1	88%	1.71 x 10 <sup>-3</sup>

Weight: BLH: 0.62 lb, BLHT: 0.66 lb.  
Output Backlash: ≈1°.  
Max. Input Speed: 3,000 Rpm.  
Greased for Life: Shell Gadus S2 V220AD 2.

Testing in your application is necessary.  
You will need to assess duty cycles and confirm  
gearbox suitability with your own calculations.  
All figures listed are to be used for guidance only.

### Output Torque in-lb

RPM Input	Reduction Ratio	
	1:1	2:1
3000	14.6	11.7
2000	16.0	12.8
1750	16.9	13.5
1000	19.5	15.6
500	22.2	17.7
100	29.9	23.9
50	32.7	26.6
10	38.9	31.3