

BLHI40
BLHO40
BLHB40

GEARBOXES

Bevel Bore Heavy Duty Gearbox

Hardened Bevels - Bore Type 3 – 10.3 Nm **1:1 - 2:1**

BLHI40
BLHO40
BLHB40

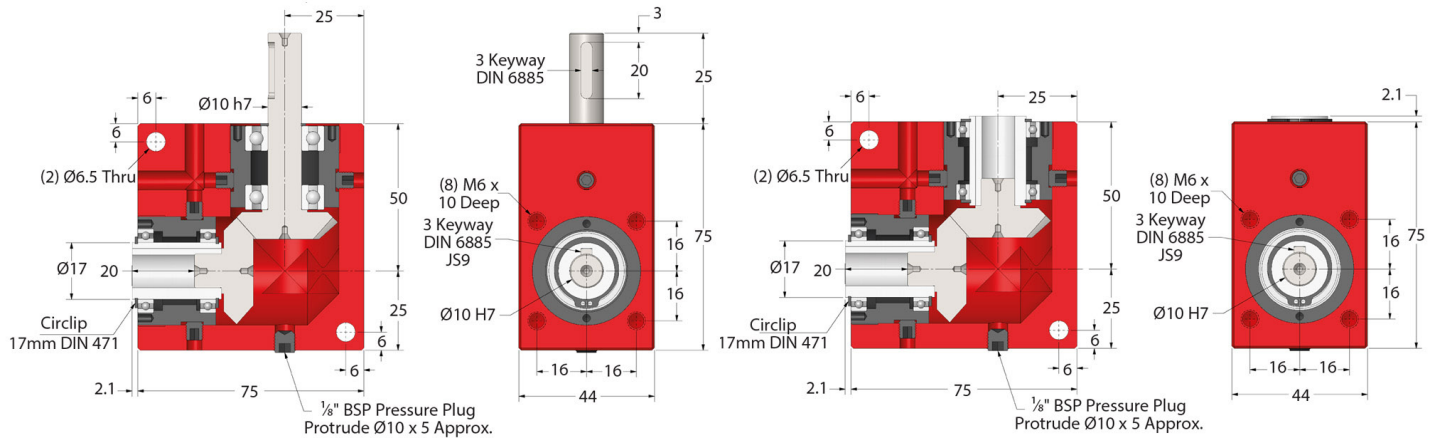
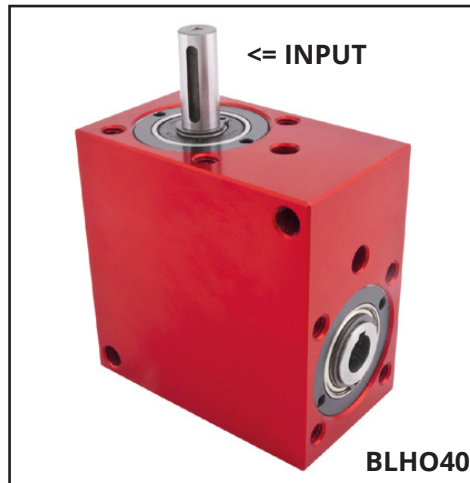
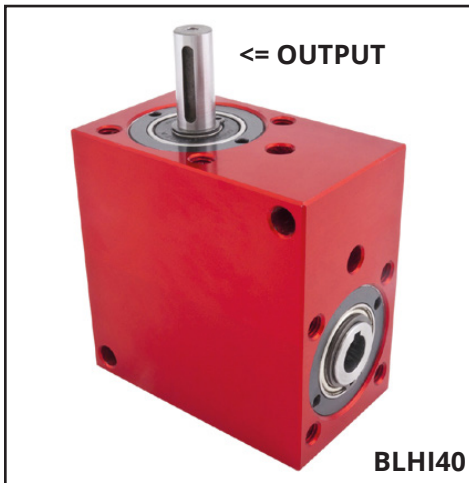

BLHI40 (Bore Input) & BLHO40 (Bore Output) Type
1:1 ratio BLHI40 only

BLHB40 Type (Bore Input & Bore Output)

Part Number			Shaft modifications also available	
Standard ≈1°	Low Backlash <30'	Red. Backlash <10'	Ratio	Efficiency at 1000 Rpm
BLHI40-1	BLHI40-1A	BLHI40-1AR	1:1	88%
BLHI40-2	BLHI40-2A	BLHI40-2AR	2:1	88%
BLHB40-1	BLHB40-1A	BLHB40-1AR	1:1	88%
BLHB40-2	BLHB40-2A	BLHB40-2AR	2:1	88%
BLHO40-2	BLHO40-2A	BLHO40-2AR	2:1	88%

Output Backlash: ≈1°.
Max. Input Speed: 3,000 Rpm.
Greased for Life: Shell Gadus S2 V220AD 2.
Bore & Shaft Key: KK3-20.

Testing in your application is necessary.
You will need to assess duty cycles and confirm gearbox suitability with your own calculations.
All figures listed are to be used for guidance only.

Output Torque Nm

RPM Input	Reduction Ratio	
	1:1	2:1
3000	4.0	3.0
2000	4.4	3.4
1750	4.6	3.6
1000	5.1	4.0
500	5.8	4.6
100	7.6	6.0
50	8.5	6.3
10	10.3	8.0

ondrives.us

1-888-260-7466
516-771-6444

sales@ondrivesus.com
www.ondrivesus.com