

BLHI50
BLHO50
BLHB50

GEARBOXES

Bevel Bore Heavy Duty Gearbox

Hardened Bevels - Bore Type 7.7 – 30 Nm **1:1 - 2:1**

BLHI50
BLHO50
BLHB50

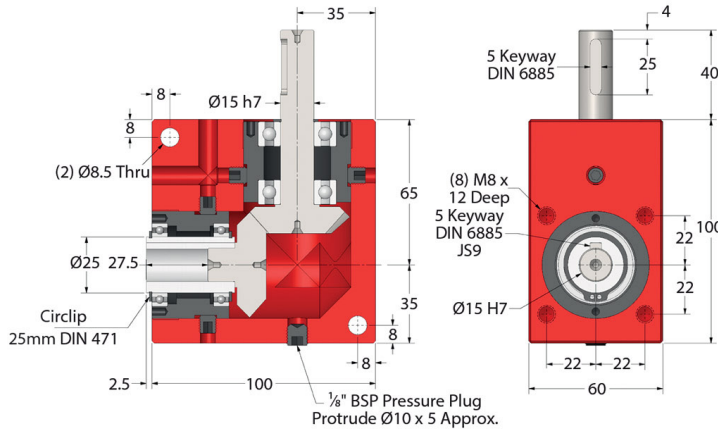
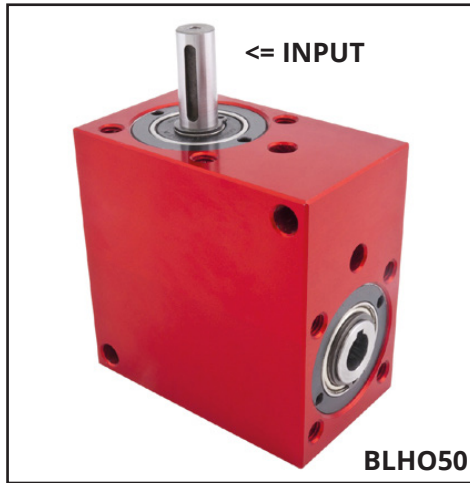
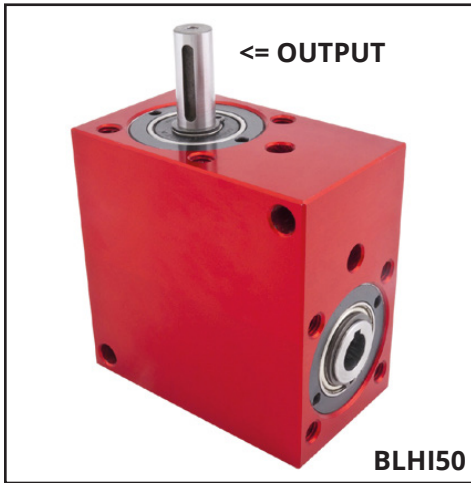

BLHI50 (Bore Input) & BLHO50 (Bore Output) Type
1:1 ratio BLHI50 only

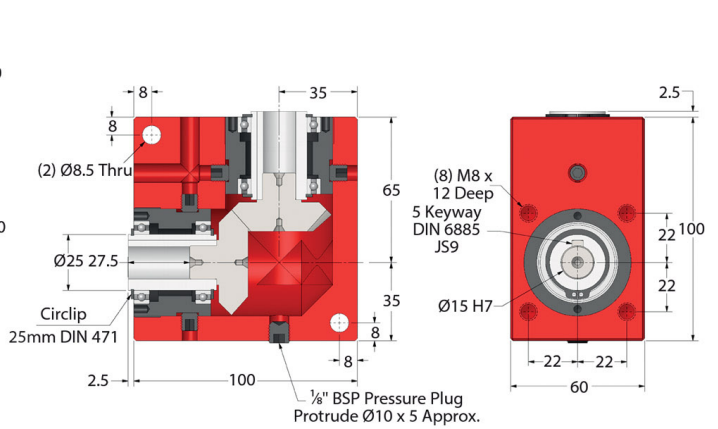

BLHB50 Type (Bore Input & Bore Output)

Part Number			Shaft modifications also available	
Standard $\approx 1^\circ$	Low Backlash <30'	Red. Backlash <10'	Ratio	Efficiency at 1000 Rpm
BLHI50-1	BLHI50-1A	BLHI50-1AR	1:1	88%
BLHI50-2	BLHI50-2A	BLHI50-2AR	2:1	88%
BLHB50-1	BLHB50-1A	BLHB50-1AR	1:1	88%
BLHB50-2	BLHB50-2A	BLHB50-2AR	2:1	88%
BLHO50-2	BLHO50-2A	BLHO50-2AR	2:1	88%

Output Backlash: $\approx 1^\circ$.
Max. Input Speed: 3,000 Rpm.
Greased for Life: Shell Gadus S2 V220AD 2.
Bore & Shaft Key: KK5-25.

Testing in your application is necessary.
You will need to assess duty cycles and confirm gearbox suitability with your own calculations.
All figures listed are to be used for guidance only.

Output Torque Nm

RPM Input	Reduction Ratio	
	1:1	2:1
3000	11.5	7.7
2000	13.2	8.7
1000	15.9	10.2
500	17.5	11.6
100	23.0	15.0
50	25.0	17.0
10	30.0	20.0

ondrives.us

☎ 1-888-260-7466
📄 516-771-6444

💻 sales@ondrivesus.com
🌐 www.ondrivesus.com