

BLHI60  
BLHO60  
BLHB60

# GEARBOXES

## Bevel Bore Heavy Duty Gearbox

Hardened Bevels - Bore Type 19 - 70 Nm **1:1 - 2:1**

BLHI60  
BLHO60  
BLHB60

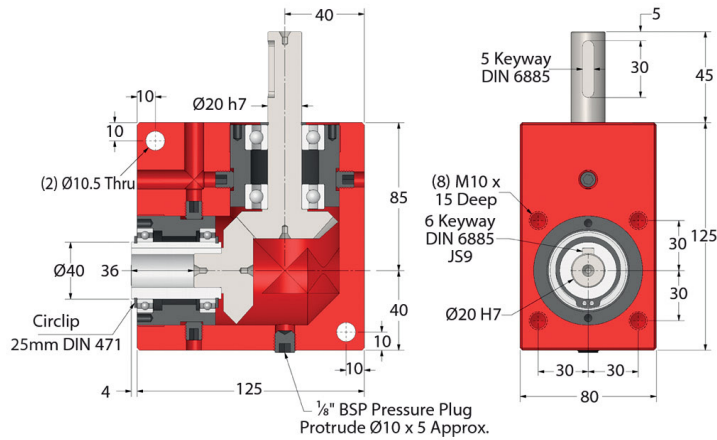
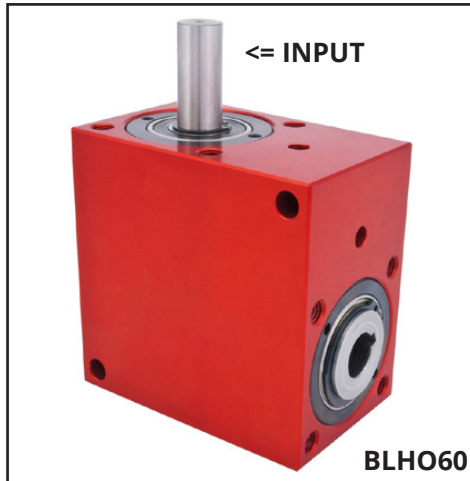
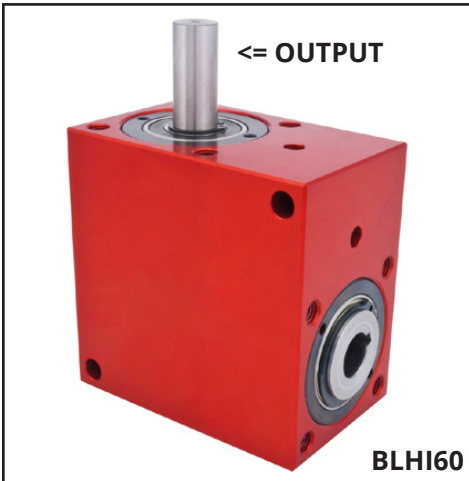

BLHI60 (Bore Input) & BLHO60 (Bore Output) Type  
1:1 ratio BLHI60 only

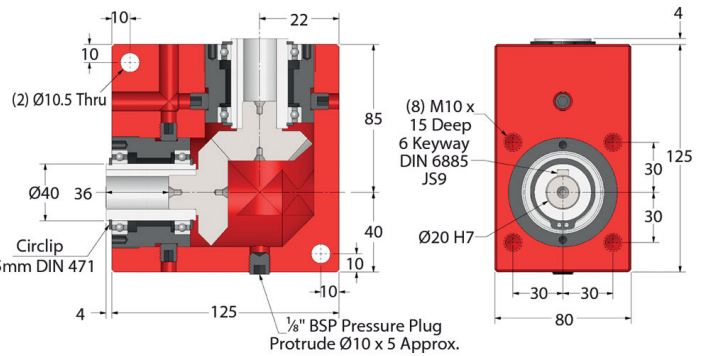

BLHB60 Type (Bore Input & Bore Output)

Part Number			Shaft modifications also available	
Standard $\approx 1^\circ$	Low Backlash <30'	Red. Backlash <10'	Ratio	Efficiency at 1000 Rpm
BLHI60-1	BLHI60-1A	BLHI60-1AR	1:1	88%
BLHI60-2	BLHI60-2A	BLHI60-2AR	2:1	88%
BLHB60-1	BLHB60-1A	BLHB60-1AR	1:1	88%
BLHB60-2	BLHB60-2A	BLHB60-2AR	2:1	88%
BLHO60-2	BLHO60-2A	BLHO60-2AR	2:1	88%

Output Backlash:  $\approx 1^\circ$ .  
Max. Input Speed: 3,000 Rpm.  
Greased for Life: Shell Gadus S2 V220AD 2.  
Bore & Shaft Key: KK5-30.

Testing in your application is necessary.  
You will need to assess duty cycles and confirm  
gearbox suitability with your own calculations.  
All figures listed are to be used for guidance only.

### Output Torque Nm

RPM Input	Reduction Ratio	
	1:1	2:1
3000	26.0	19.0
2000	30.0	22.0
1750	31.3	22.8
1000	35.0	25.0
500	40.0	29.0
100	53.0	38.0
50	57.0	43.0
10	70.0	52.0

**ondrives.us**

1-888-260-7466  
516-771-6444

sales@ondrivesus.com  
www.ondrivesus.com